

THE  
GERBER  
VARIABLE SCALE<sup>®</sup>

AN APPLICATION AND  
INSTRUCTION MANUAL

by

H. JOSEPH GERBER  
PRESIDENT

THE GERBER SCIENTIFIC INSTRUMENT COMPANY  
P. O. BOX 305  
Hartford, Connecticut

NO. 400

Copyright 1953

THE GERBER SCIENTIFIC INSTRUMENT CO.

Hartford 1, Connecticut

All rights reserved

REPRINTED 1960

REPRINTED 1962

REPRINTED 1963

REPRINTED 1964

REPRINTED 1965

REPRINTED 1966

REPRINTED 1967

REPRINTED 1969

REPRINTED 1976

REPRINTED 1977

REPRINTED 1978

REPRINTED 1979

REPRINTED 1980

REPRINTED 1981

REPRINTED 1984

## INDEX

	page
Introduction	3
Construction	4
Adjustment	5
Care and Use	5
Parts List	6

### PART "A"

#### TYPICAL PROBLEMS INVOLVING ONLY THE "CALIBRATOR SPRING"

Graphical numerical multiplication*	9
Graphical numerical division*	10
Graphs difficult to read	11
Odd scale drawing reproductions	12
Normalizing curves	
Family of curves - linear interpolation	14
Family of curves - plotting test points	15
Counting cycles, obtaining frequencies	16
"Pantograph"	17
Graphical division-dividing one curve by another curve	18
Pressure ratio from monometer recording	19
Navigation	20
Center of gravity	21

#### TYPICAL PROBLEMS INVOLVING THE RECIPROCAL SCALES

Scale factor on oscillograms	23
Reading aerial photographs	24
Spacing rivets	25
Infinitely variable engineering scale	26

#### TYPICAL PROBLEMS INVOLVING LINEAR SCALES

Scaling accurately very small lengths	28
Laying out an airfoil section	29

\* Further reference, Part #C, showing the positioning of the decimal point.

## PART "B"

Problems involving the reading, plotting or interpolating of logarithmic scales. The use of this function requires the locating of a "Constant".

### LOGARITHMIC SCALES

Interpolate logarithmically between curves	33
Power ratio of curves	34

## PART "C"

APPENDIX tables showing the location of the decimal point in graphical numerical calculations.

APPENDIX	35 - 39
----------	---------

## INTRODUCTION

The Gerber Variable Scale is a unique engineering instrument which represents a new philosophy in the field of computation. It is an easy-to-use, manually operated, mechanical device. It performs computations directly on graphs, curves, recordings, and is used on graphical work where reading, plotting and interpolating is of the essence.

It saves an enormous amount of time in the reading of recordings such as oscillograms or telemetering data because to a large extent it eliminates the drudgery involved in data reduction. It also saves a great deal of time in the plotting of graphs and curves, especially in the direct multiplication and division of graphical functions, and in the reading thereof.

The Gerber Variable Scale has two springs - a calibrated triangular spring and a number spring. Both are fixed at the left ends and are attached at the right end to a slide.

The triangular spring is the heart of the instrument. It has 100 calibrated coils, of which every fifth is colored blue-green, every tenth red and the others white.

The round spring is auxiliary to the triangular spring, and expands and contracts with it. It carries little discs reading 0, 2, 4, 6, 8 and 10 which correspond to and calibrate the 0, 20th, 40th, 60th, 80th and 100th coils on the triangular spring. Its function is to facilitate the more rapid reading of the coils of the triangular spring.

Both springs are enclosed in a plastic crystal which is optically designed to project the calibrating lines of the triangular spring outward to the outer surface as well as downward to the bottom or working surface.

The spring itself is used directly in linear computations such as: multiplying curves by constants or by variables directly; for interpolating between families of curves; for plotting of test points where the parameter is difficult to hold on account of varying physical conditions.

Assuming that certain amplitudes have to be read on film or tape, it is only necessary to know either one amplitude in the final numerical value, or the calibration factor. The triangular spring whose coils represent the calibration lines of a scale can be extended so that the numerical value of that amplitude equals the number of coils. Suppose, for example, that a given amplitude should read 25,400 p.s.i. Extend the spring so that 25.4 coils cover the height of the amplitude. With the spring locked in this position, the instrument can be moved to scale all other amplitudes in their final corrected values. In this instance, one can readily note that if the amplitudes were read in inches, centimeters, or any other linear scale it would still be necessary to convert the readings to final answers by multiplying through with calibration factors or constants. It is this conversion that is extremely tedious and unnecessary in a great many cases. Considering the reading of values and the multiplying through by constants equal in time, the engineering time can be halved by the use of the Gerber Variable Scale.

## CONSTRUCTION

The heart of the Gerber Variable Scale is a triangular spring, fixed at the left end, and attached at the right to a slide. Fastened in a similar manner is a round spring carrying little discs with numbers to facilitate easier reading of the triangular or "Calibrator" spring.

The triangular spring has 103 coils of which only 100 coils are calibrated. A color scheme is used to subdivide the 100 coils into tens and fives, where every tenth coil is marked red and every fifth coil blue-green. The round spring carries the numbers 0, 2, 4, 6, 8 and 10 to calibrate the 0, 20, 40, 60, 80 and 100 coils of the triangular spring. Thus, when the slide is moved, both springs are therefore extended to the same distance, and the same numbers calibrate the same coil. Both springs are protected by an optically designed crystal.

The main body of the instrument is made of aluminum. Both the left and right ends as well as the thin strip of aluminum over which the springs float are cemented to the base. The slide, designed to be self-locking in any position, can easily be adjusted to the desired friction by means of two set screws. The slide also carries a hairline indicator which is held in place by two screws. The holes in the plastic with the hairline are oversized to permit relative adjustment.

A plaque containing three scales is held to the base by two screws. It has two oversized holes, permitting additional adjustment. The plaque is easily removable.

The "Calibrator" spring is fastened to the left end piece and slide by means of screws. These screws pass through a horizontal slot. For purposes of adjustment, these screws can be loosened and the spring adjusted in the horizontal plane.

The friction of the slide is adjustable by loosening or tightening the set screws. It is necessary to move the slide toward the center of the base, so that either set screw lines up with the hole in the base. A wrench is included with each instrument to fit the set screws.

## ADJUSTMENT

To insure proper accuracy, the instrument should be checked from time to time depending on the use as well as the type of application. The following procedure is recommended:

- a.) Move the slide toward the left end until the spring measures 1.00 inches. Use an accurate decimal scale and check the line-up of the red coils with every tenth calibration of the decimal scale.
- b.) Loosen the screws on the slide holding the hairline indicator. Line up the hairline so that it passes through 100 on the  $R_1$  scale and tighten the screws.
- c.) If the hairline does not quite reach these two scales, it may be necessary to loosen the screws on the plaque containing the three scales and to move the plaque in the direction and a little beyond the hairline. Then repeat step "b"
- d.) Extend the calibrator spring until it measures 10.00 inches. Also check the line-up of the red coils with the inch calibrations on the decimal scale.

## CARE AND USE

The Gerber Variable Scale is a scientific instrument and should be treated as such. Even though it is ruggedly designed, and the spring packages protected by a crystal, the scale must not be dropped or subjected to high accelerations.

The plastic cover or crystal is designed for strength as well as to project the calibrating lines of the spring to the outer surface of the crystal as well as downward to the bottom or working surface. To obtain the greatest reading accuracy and the best reading quality, it is recommended that the user views the lines of the spring in a plane perpendicular to the axis of the spring containing the coil in question, and at an angle of about 110 degrees with the base, or about 70 degrees with the working sheet.

## PARTS LIST

When ordering parts for the Gerber Variable Scale give the diagram number, name of the part and the instrument model number. For instance, when ordering a new triangular spring, the order should contain this description: #10 - Calibrator Spring Package - TP007100B

### Parts:

- #1 Aluminum strip (fixed to base)
- #2 Aluminum base
- #3 Inertia rod
- #4 Crystal
- #5 Left end connection (Aluminum, fixed to base)
- #6 Right end connection (Aluminum, fixed to base)
- #7 Scale insert (removable unit)
- #8 Slide
- #9 Plastic hairline indicator
- #10 Calibrator spring package (consisting of left and right end connections and triangular calibrated spring)
- #11 Screw
- #12 Screw
- #13 Number spring package (consisting of left and right end connections and round spring with numbers)
- #14 Screw
- #15 Plastic bearing
- #16 Friction plug
- #17 Set screws
- #18 Screw
- #19 Screw
- #20 Screw
- #21 Screw
- #22 Washer
- #23 Allen wrench\*
- #24 Instrument case\*
- #25 Plastic storage envelope\*

\*NOT ILLUSTRATED



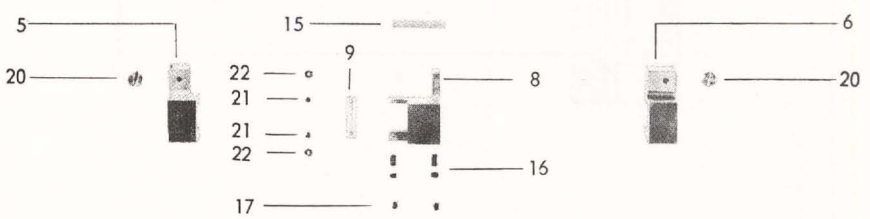
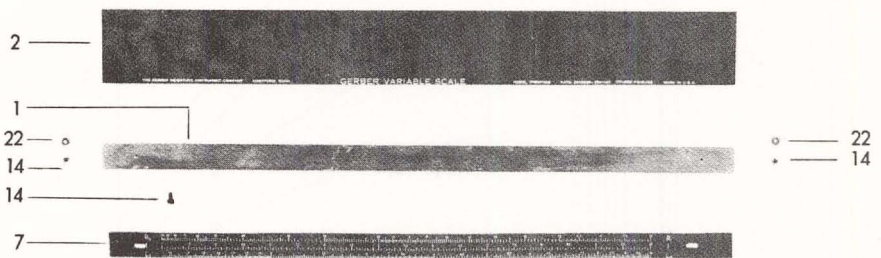
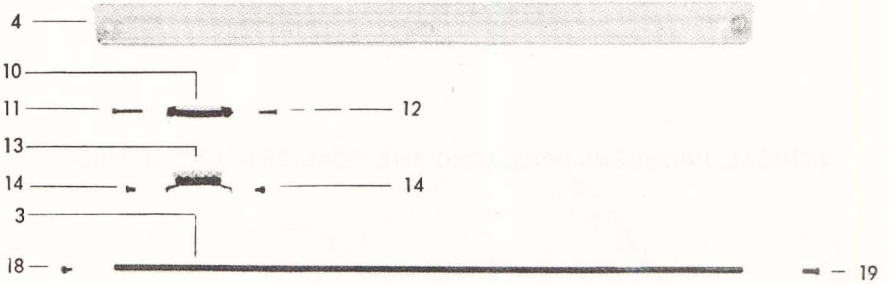

ILLUSTRATED PARTS BREAKDOWN

TYPICAL PROBLEMS INVOLVING THE "CALIBRATOR" SPRING

PART "A"

## GRAPHICAL-NUMERICAL MULTIPLICATION

Many times curves are plotted, yet should be replotted either as a family of curves or multiplied by constants. The example shown illustrates one of the principle characteristics of the instruments. Instead of 1) reading a point, 2) multiplying this value by a number, and 3) replotting the new point, the Gerber Variable Scale performs these operations directly, thus saving much valuable engineering time especially where such graph plotting is done.

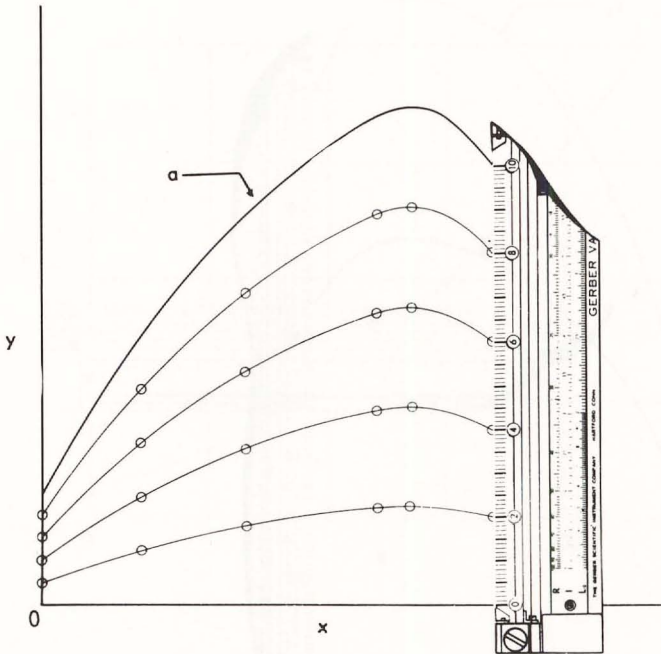

### PROBLEM: Multiplication

A curve "a" is drawn. Plot a family of curves with values of 0.2a; 0.4a; 0.6a; 0.8a; 1.0a.

### SOLUTION:

Place the Gerber Variable Scale along any point "x" parallel to ordinate with the 0 coil at  $y=0$ , and the 100 coil at curve "a". Mark off points at 20, 40, 60 and 80 coils. Move the instrument to other stations "x" and repeat the procedure. Finally draw a curve through equal % points.

Note: a graph grid is not used in these calculations and is completely unnecessary.

## GRAPHICAL-NUMERICAL DIVISION

Often a curve is plotted or recorded and must be replotted to pass through a given point, or it must be divided by a correction factor. The Gerber Variable Scale performs such operations directly eliminating graphical-numerical conversions, thus saving much time.

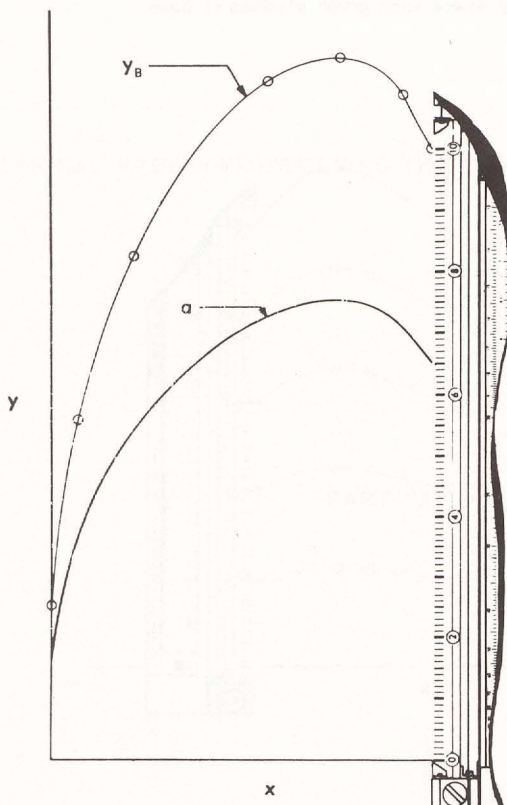

### PROBLEM: Division

Given curve "a". Plot a new curve, proportional to curve "a" and passing through point " $y_B$ ".

### SOLUTION:

Place the Gerber Variable Scale on curve "a" parallel to ordinate with the 0 coil at  $y=0$  and the 100 coil at " $y_B$ ". Read the number = 64.6 on the spring at " $y_A$ ". This value is the divisor of curve "a". Slide the instrument to other values "x", always parallel to the ordinate, extend or compress the spring keeping the divisor always on curve "a", and mark off the corresponding points at the 100 coil. Finally connect these points with a curve.

## GRAPHS DIFFICULT TO READ

Data plotted in publications is oftentimes recorded on a very coarse grid graph paper. Also the units in which this plot is made must frequently be changed and replotted to suit the application. The Gerber Variable Scale is most useful and time saving since it allows for the direct reading.

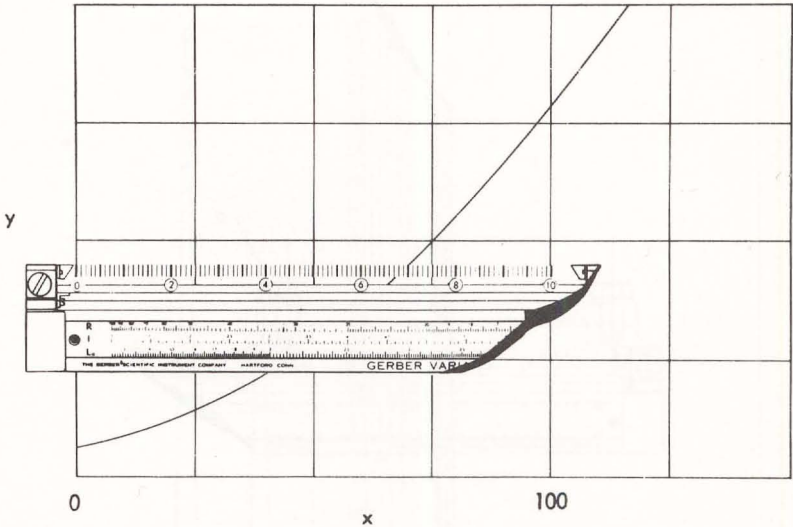

### PROBLEM:

On the curve shown above, make a scale along the abscissa to read closer subdivisions.

### SOLUTION:

Set the 0 coil at  $x = 0$  and stretch the spring so that the 100 coil coincides with  $x = 100$ . Then use the Gerber Variable Scale to scale off points on the curve.

Note: Should for instance the problem require the multiplying of the  $x$  values by a factor of .865, merely set 86.5 coils at  $x = 100$  and scale the values off directly, already multiplied by 865.

## ODD SCALE DRAWING REPRODUCTIONS

Many times it is impossible to obtain the original drawings and copies or reproductions must therefore be scaled. The Gerber Variable Scale gives the desired scales immediately by either knowing one dimension of the drawing or the scale factor.

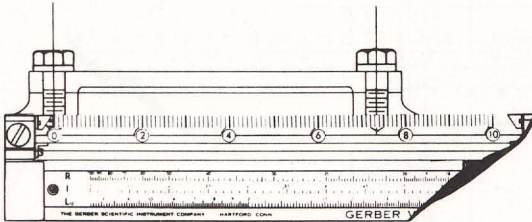

### PROBLEM:

On a cover plate the bolt diameter is known to be .500 inches. Find the distance between the center lines of the bolts.

### SOLUTION:

Set the 0 coil at the centerline and the 2.5 coil at the right side of the left bolt.  
Read the distance between centerlines = 7.34 inches.

## NORMALIZING CURVES

In order to compare various points on a curve to the maximum value of the curve, or different amplitudes on an oscillogram recording to a maximum amplitude, the reference value can be set at once with the Gerber Variable Scale.

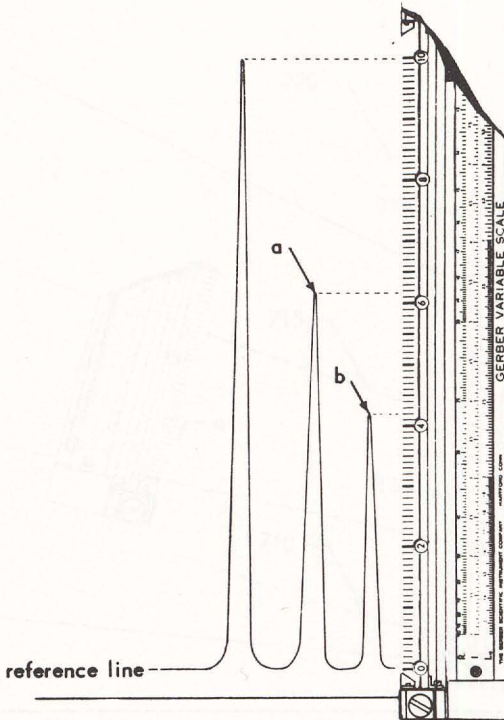

### PROBLEM:

On a mass spectrometer recording, determine values of curves "a" and "b" in terms of the maximum amplitude.

### SOLUTION:

Set the 0 coil on the horizontal reference line and the 100 coil at the peak of the maximum amplitude. Then read amplitudes "a" and "b" in terms of the established scale, which are .613 and .418 respectively.

## FAMILY OF CURVES - - LINEAR INTERPOLATION

A large number of engineering calculations require either the interpolating of a family of curves, or the plotting of closer spaced parameters. If the curves are fairly linearly spaced, the spring can be used directly to perform these operations.

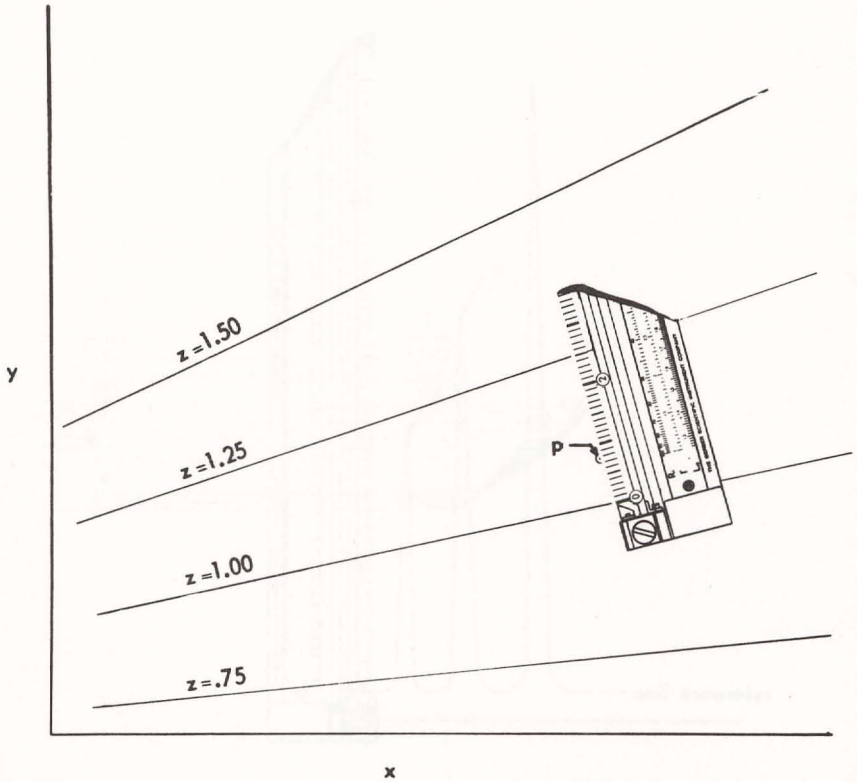

### PROBLEM:

In the graph given, find the value of point "p".

### SOLUTION:

(For purposes of standardization, the best way to interpolate curves is to place the instrument perpendicular to the bisecting angle of the two curves in question.) Place the instrument as shown. Set the 0 coil at curve  $z = 1$ , and the 25 coil at  $z = 1.25$ . Read the value of point "p" = 1.078.



## FAMILY OF CURVES - - PLOTTING TEST POINTS

In plotting surveying data such as elevation contours, it is very rare that the values for the points taken are in an arithmetical progression.

Similarly, when plotting test points representing a parametric function, it is many times impossible or too involved to control ordinate or abscissa values to obtain readings of the parameter either as constant values in an arithmetic progression or in a desired sequence of whole numbers. Assuming a linear relationship in this example, the spring can be used by itself to give rapid answers.

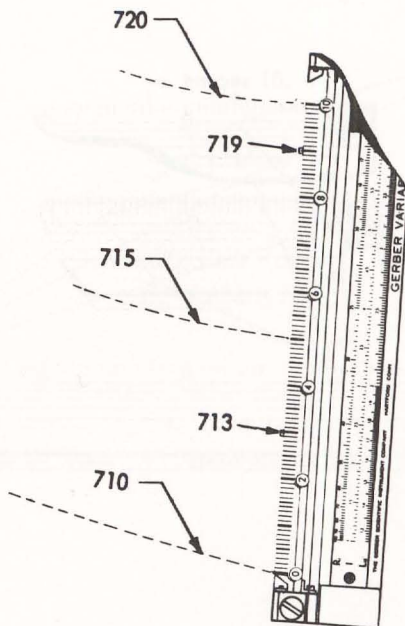

### PROBLEM:

Given elevation points, #713 and #719. Locate the station for 715 and 720 feet and plot the contour.

### SOLUTION:

The numerical difference between 713 and 719 is 6 feet. Set the 0 coil at point 713 and the 60 coil at point 719. With the spring locked in position, place the instrument so that the 30 coil is at 713 and the 90 coil should coincide with the station 719. Then mark off stations 710 feet, 715 feet and 720 feet. Repeat procedure for other sections and connect points of equal elevation with a curve.

## COUNTING CYCLES - - OBTAINING FREQUENCIES

Counting a number of cycles or dots is very tedious and eye-straining especially if they are closely spaced. The Gerber Variable Scale is well suited to counting lines or dots even though they may not be quite evenly spaced.

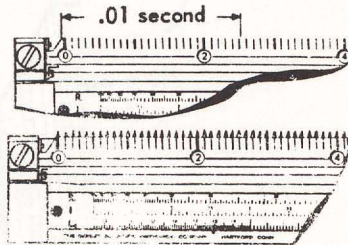

### PROBLEM:

Given a pattern of cycles and timing lines, determine the frequency.

### SOLUTION:

Set the 0 coil at the zero reference cycle and expand the spring until coil 1 coincided with the cycle 1. If the spacing between all cycles is uniform, then coil 2 should line up with cycle 2, coil 3 with cycle 3, etc. However, if this is not the case, read from left to right, adjusting the slide to bring successive cycles in alignment with the coils. This will "average your count". Keep the spring locked in position, set the instrument over the timing lines and read the frequency = (25.8 coils) = 2580 cps.

## PANTOGRAPH

Reducing or enlarging diagrams for reports is very tedious. Since the Gerber Variable Scale multiplies and divides distances very simply, it is well suited for many pantograph applications.

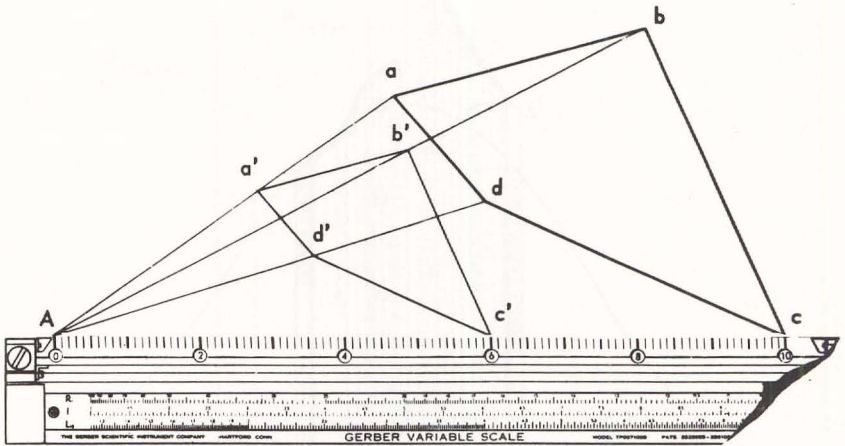

### PROBLEM:

Replot figure  $abcd$ , so that its dimensions are 60% of the original value. New figure  $a'b'c'd'$  is symmetrical to  $abcd$ .

### SOLUTION:

Select an arbitrary point "A". Place the Gerber Variable Scale along  $Aa$  with the 0 scale at "A" and the 100 coil at "a" and plot the point  $a'$  at the 60 coil. Repeat the operations along  $Ab$ ,  $Ac$ , and  $Ad$  marking the respective 60 coils to locate  $b'$ ,  $c'$  and  $d'$ .

## GRAPHICAL DIVISION - DIVIDING ONE CURVE BY ANOTHER CURVE

The problem of dividing one length into another length is present in many analytical-design problems, or in analyzing recorded curves. A typical example is the reading of curve ratios on infra-red recordings where three curves represent different variables.

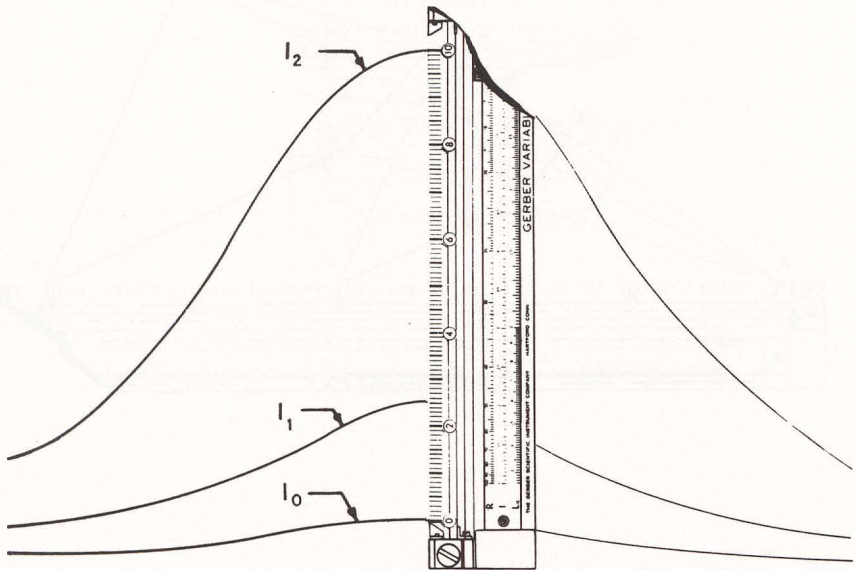

### PROBLEM:

Determine the ratio of  $\frac{I_1 - I_0}{I_2 - I_0}$

### SOLUTION:

Set the 0 coil on curve  $I_0$  and the 100 coil on curve  $I_2$ . Read the desired ratio at curve  $I_1 = .252$ .

## PRESSURE RATIO FROM MONOMETER RECORDING

The rise of liquids is often photographically recorded for analysis. Since one setting of the Gerber Variable Scale will directly divide one length by another length, ratios of static pressure to the total pressure can directly be obtained.

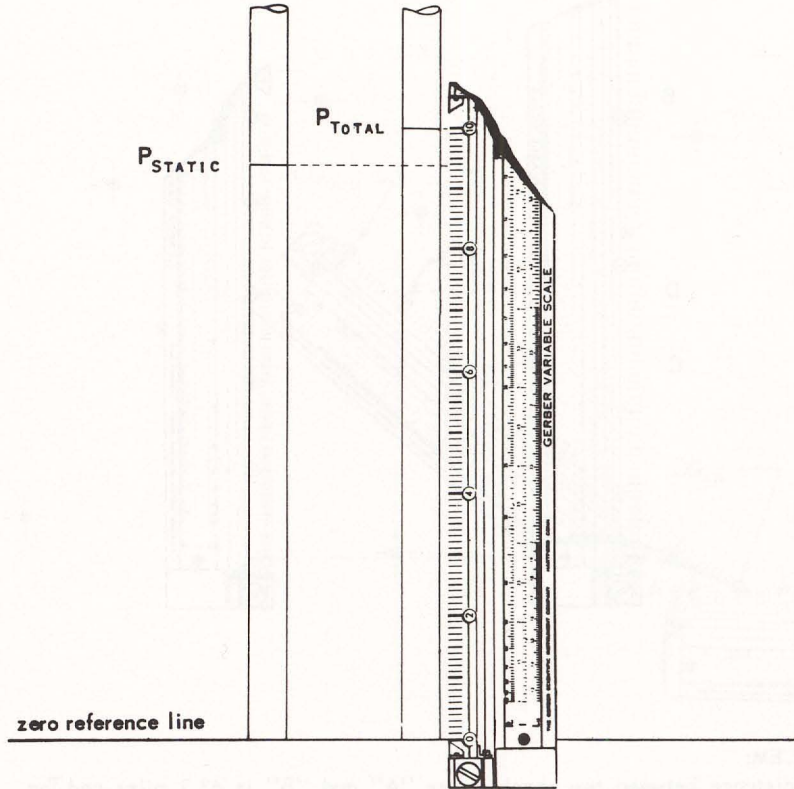

**PROBLEM:**

Read

$$\frac{P_{\text{STATIC}}}{P_{\text{TOTAL}}}$$

**SOLUTION**

Set the 0 coil at the zero reference line and the 100 coil at  $P_{\text{TOTAL}}$ . Read the pressure ratio at  $P_{\text{STATIC}}$  .937.

## NAVIGATION

Time, distance and velocity problems can readily be solved with the Gerber Variable Scale. Because the spring represents an infinitely variable scale, computations can directly be made from aerial photographs as well as from maps.

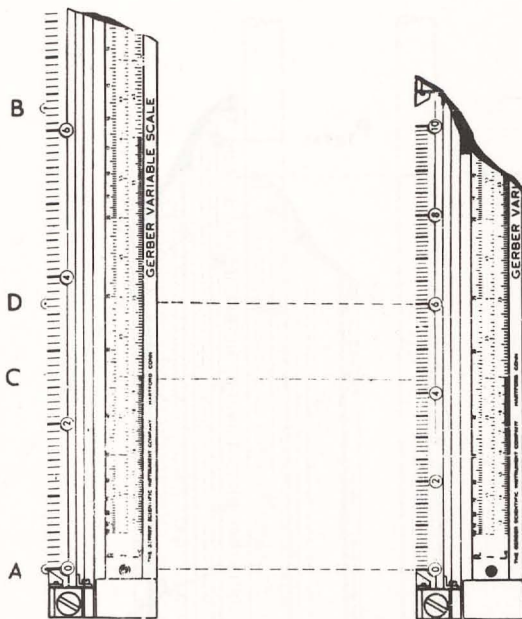

### PROBLEM:

The distance between two check points "A" and "B" is 63.2 miles and The velocity in mph = 36.6. Determine

- 1) Distance AC
- 2) Time traveled in distance AC
- 3) Mark off every ten minutes on course

### SOLUTION:

- 1) Set the 0 coil at "A" and the 63.2 coil at "B". Read AC = 26.3 miles
- 2) Keep the same setting and mark off point "D" at 36.6 coil. This represents one hour. Compress the spring so that the 60 coil is at point "D" and read 43.1 minutes at point "C"
- 3) Mark off every tenth coil.

## CENTER OF GRAVITY

The determination of a center of gravity of a rivet pattern can become quite tedious. Many times after a center of gravity has been located, stress calculations show that some rivets are overstressed and that additional rivets are necessary to lower the stress level.

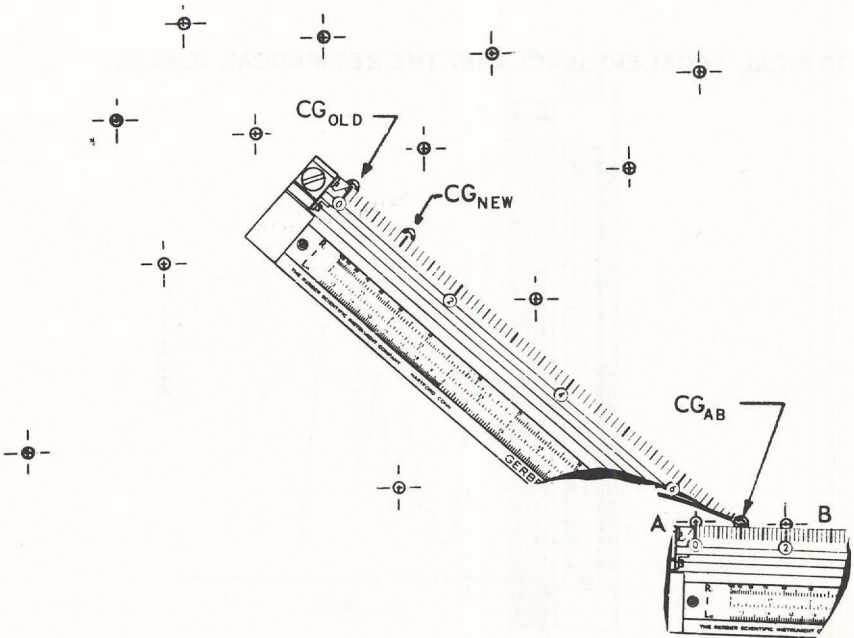

### PROBLEM:

Given the center of gravity of a rivet pattern  $CG_{OLD}$ , determine the location of the new C.G. for the addition of rivets "A" and "B"

### SOLUTION:

Set the 0 coil at "A" and the 20 coil at "B" and mark point " $CG_{AB}$ " at the 70 coil. This is the center of gravity of the rivet pattern AB. The old rivet pattern has 12 rivets and the new rivet pattern has 14 rivets; therefore, set the 0 coil at " $CG_{OLD}$ " and the 70 coil at " $CG_{AB}$ " and mark off " $CG_{NEW}$ " at the 10 coil.

## TYPICAL PROBLEMS INVOLVING THE RECIPROCAL SCALES

### PART "A"



## SCALE FACTORS ON OSCILLOGRAMS

In scaling linearly amplitudes on an oscillogram recording, scale factors converting inch readings to the final results are either given or are to be obtained.

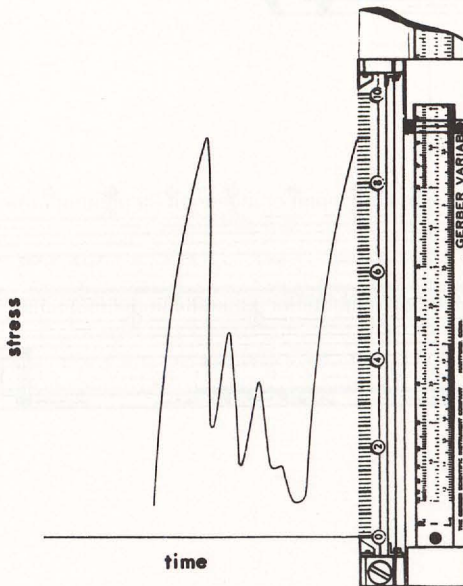

### PROBLEM:

Read a strainage recording where 1 inch amplitude = 18,730 psi. Also include a correction factor = .924.

### SOLUTION:

1 inch =  $(18,730)(.924) = 17,310$  psi. Set the hairline to 17.31 on the R scale. Every coil represents 1000 psi. Scale off the stress with the spring.

## READING AERIAL PHOTOGRAPHS

For purposes of aerial surveying or armed forces intelligence work, scales can be set immediately with the Gerber Variable Scale to read aerial photographs. Also these photographs can immediately be classified.

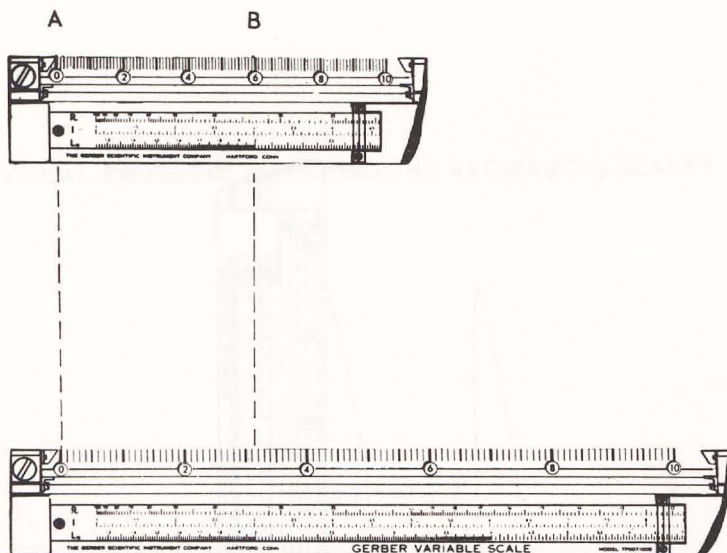

### PROBLEM

The distance between the intersection of two roads is known to be .592 miles.

Make scales to read the photograph in:

1a) Miles	1b) Miles per inch
2a) Feet	2b) Feet per inch

### SOLUTION:

1a) Set the coil 0 at intersection "A", and the .592 coil at the intersection of "B". This is the scale in miles. Every coil represents .01 miles.

1b) At the hairline read the scale factor. 2,305 miles per inch on the  $R_1$  scale

2a)  $(.592)(5280) = 3,126$  feet. Set the 0 coil at "A" and the 31,3 coil at "B". This is the scale in feet. Every coil represents 100 feet.

2b) At the hairline read 12170000 feet per inch.

## SPACING RIVETS

To lay off equally spaced lengths can become very tedious and produces accumulative errors as well. The Gerber Variable Scale can be used directly to divide any given length into any number of equally spaced lengths, as well as plot any number of equally spaced divisions per inch.



### PROBLEM:

On a sheet metal plate lay off the centers for equally spaced rivet holes at 1.211 per inch.

### SOLUTION:

Set the hairline indicator at 12.11 on the  $R_1$  scale and mark the rivet hole centers at every tenth coil.

## INFINITELY VARIABLE ENGINEERING SCALE

Engineering scales are limited to a fixed number of sub-divisions such as 10, 20, 30, 40, etc. divisions per inch. However, when a special scale of say 12.96 divisions per inch is required, such a scale has to be made up special. Since the expansion ratio of the springs in the Gerber Variable Scale is 10 to 1, any desired scale can be set up at once.

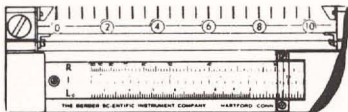
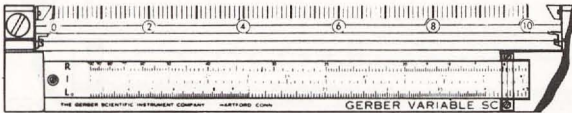

### PROBLEM

Make the following scales:

- 10.77 divisions per inch
- 15.87 divisions per inch
- 21.9 divisions per inch

### SOLUTION:

Set the indicator at:

- 10.77 on the  $R_1$  scale
- 15.87 on the  $R_1$  scale
- 21.9 on the  $R_1$  scale.

TYPICAL PROBLEMS INVOLVING THE LINEAR SCALES



PART "A"

## SCALING ACCURATELY VERY SMALL LENGTHS

The Gerber Variable Scale is very adaptable to the scaling of lengths less than one inch. It makes use of the fact that by setting the 0 and 10 coils at the limits of the length to be scaled, the 100 coil represents ten times this distance which is automatically indexed at the linear scales. This system is much easier on the eyes of the user because it requires much less strain to sight down on a line and move it until it coincides with the point in question, rather than interpolate the limit point in question on a finely subdivided scale in thousandths. Whatever small error may occur on lining up the points in question with the coils on the Gerber Variable Scale, is not multiplied by ten. For instance, if an error of  $-.004$  inches should be made in lining up the tenth coil, and the distance to be scaled is  $.831$  inches, then the reading on the I scale would be  $8.27$  inches. Yet the decimal point has to be moved to the left because the reading is only one tenth of this value or  $.827$  inches, or the error is in the thousandths of an inch.

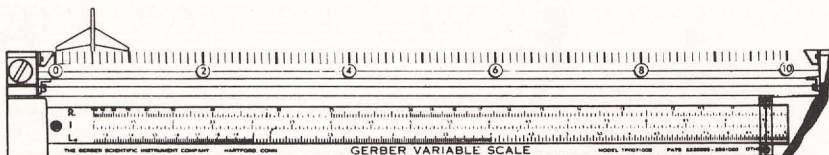

### PROBLEM:

On an aerial photograph shown above, scale the span of the wing. Read the answer in inches.

### SOLUTION:

Set the 0 coil at the left tip and the 10 coil at the right tip of the wing. Read the length of span on photograph in thousandths of an inch on the I scale.  
Answer =  $0.952$  inches.

## LAYING OUT AN AIRFOIL SECTION

Most airfoil data is tabulated in percent of chord. Since there are 100 calibrated coils on the triangular spring and the setting of the chord length on these scales will automatically produce a scale from which the percent chord values can be plotted directly.

Should the chord length be over ten inches, say 83.4 inches, the setting on the I scale will be 8.34 and 100 coils represent 10 percent of the chord. In other words, each coil represents 0.1 percent of the chord. To lay off the mean camber line and the thickness, which are also given in percent chord, these values can also be plotted directly from the percent data.

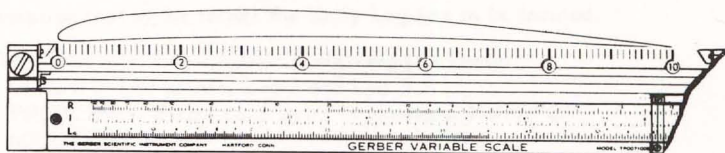

### PROBLEM:

Lay out an airfoil section with a chord length = 8.16 inches.

### SOLUTION:

Set the hairline at 8.16 on the I scale. Lay off the various percent chord points directly. Keeping the slide locked in place, lay off the mean camber line and the thicknesses.

PROBLEMS INVOLVING THE LOCATING OF A CONSTANT

PART "B"



## HOW TO USE THE VARIOUS SCALES FOR READING, PLOTTING AND INTERPOLATING

The mechanics involved is similar in the usage of the various scales. Since the I scale is a linear scale, this procedure is not necessary because the "calibrator" spring can be used directly. The reciprocal scale has its own field because it determines the number of coils per inch. However, its function can also be reproduced in a similar manner as the log scale.

The O coil of the "calibrator" spring has the following meaning in conjunction with the  $R_1$  and  $L_{10}$  Scale.

Type of Scale	Full Name	O Coil
$R_1$	Reciprocal Inch	Infinity
$L_{10}$	Logarithmic, base 10	1

As pointed out earlier, in order to use the logarithmic scale, it is necessary to determine a "Constant".

### INTERPOLATE BETWEEN GRAPHICAL LOGARITHMS:

In order to show the mechanical procedures involved, actual examples are given below. There are two types; namely: TYPE A, where the log 1, .01, 1000, etc. is known. The other type is TYPE B, which is similar to TYPE A with the exception that in the former the Unity Log has to be located.

TYPE A - - - Log 1, (.01, .1, 100, etc.) is known

GIVEN:- Two points, Log 1 and Log 5

PROBLEM:- Find Log at point in question, Point "C".

SOLUTION:

- 1) Set indicator to Log 5 on LOG SCALE ("L" SCALE)
- 2) Set 0 coil on POINT Log 1 on graph
- 3) Read "Constant" on spring at POINT Log 5 and remember value.
- 4) Move slide so that "Constant" on spring is over point in question, (POINT "C"), and read the value of Log "C" with indicator on LOG SCALE.

TYPE B - - - Log 1, (.1, 10, 100, etc.) is unknown

GIVEN:- Two points, Log 2 and Log 5

PROBLEM:- Find Log at point in question, POINT "C"

SOLUTION:

- 1) Set indicator to Log 2 on LOG SCALE and place 100 coil over POINT Log 2
- 2) Move slide to Log 5 and make a POINT "D" at 100 coil
- 3) Place 0 coil at POINT Log 2, and 100 coil at POINT "D" and read "Constant" at POINT Log 5
- 4) Set indicator to Log 5 on LOG SCALE and place instrument so that the "Constant" on spring is over POINT Log 5 (THE 0 COIL LOCATES THE LOG 1 AT LEFT. IT IS ADVISABLE TO MARK THIS POINT SINCE FURTHER INTERPOLATIONS WILL ALWAYS REQUIRE THIS POINT).
- 5) Move slide so that "Constant" on spring is over POINT "C" and read value of Log "C" with indicator on LOG SCALE

PLOT LOG SCALES:

The problems of plotting points having a logarithmic relationship are similar to those of interpolations. Again there are two types to be considered; namely, TYPE A' and TYPE B'. In TYPE A' the location of the Unity Log is known, whereas in TYPE B' the Unity Log must be located.

TYPE A' - - - Same as TYPE A

GIVEN: - - - Same as TYPE A

PROBLEM - Plot Log Scale - POINTS  $\text{Log } C_N$

SOLUTION:

- 1) Same as TYPE A
- 2) Same as TYPE A
- 3) Same as TYPE A
- 4) Set indicator of slide to values  $C_N$  Log C on LOG SCALE and plot required corresponding POINTS  $\text{Log } C_N$  at "Constant" on spring.

TYPE B' - - - Same as TYPE B

GIVEN: - - - Same as TYPE B

PROBLEM: Plot Log Scale - POINTS  $\text{Log } C_N$

SOLUTION:

- 1) Same as TYPE B
- 2) Same as TYPE B
- 3) Same as TYPE B
- 4) Same as TYPE B
- 5) Set indicator of slide to values of  $\text{Log } C_N$  on LOG SCALE and plot required corresponding POINTS  $\text{Log } C_N$  at "Constant" on spring.

## INTERPOLATE LOGARITHMICALLY BETWEEN CURVES

Families of curves often converge logarithmically in the parameter. A linear interpolation would therefore be too much in error. (Page 14 shows the process of interpolating linearly.) A similar example is shown here.

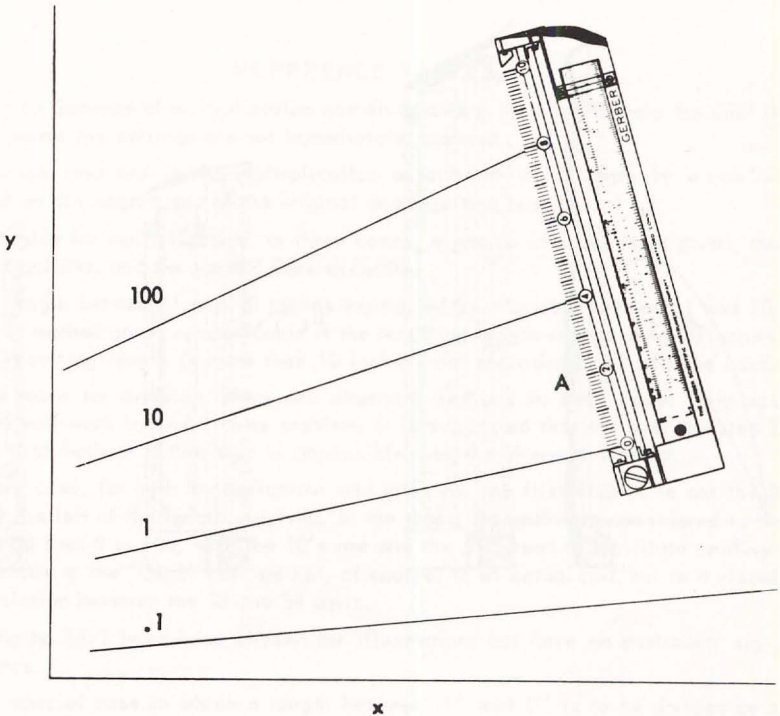

### PROBLEM:

Read point "A".

### SOLUTION:

The pattern of the family of curves shows a logarithmic parameter. Place the 0 coil at curve "1". Set the hairline to 10 on the Log<sub>10</sub> scale and read the "Constant" at curve "10". The Constant = 0.83. Compress the spring so that the Constant is at point "A" and read the answer with hairline on the Log<sub>10</sub> scale. The interpolated value of point "A" = 3.23

## POWER RATIO OF CURVES

The analysis of certain recorded curves requires the determination of a power ratio. The  $\text{Log}_{10}$  scale on the Gerber Variable Scale is used for this computation.

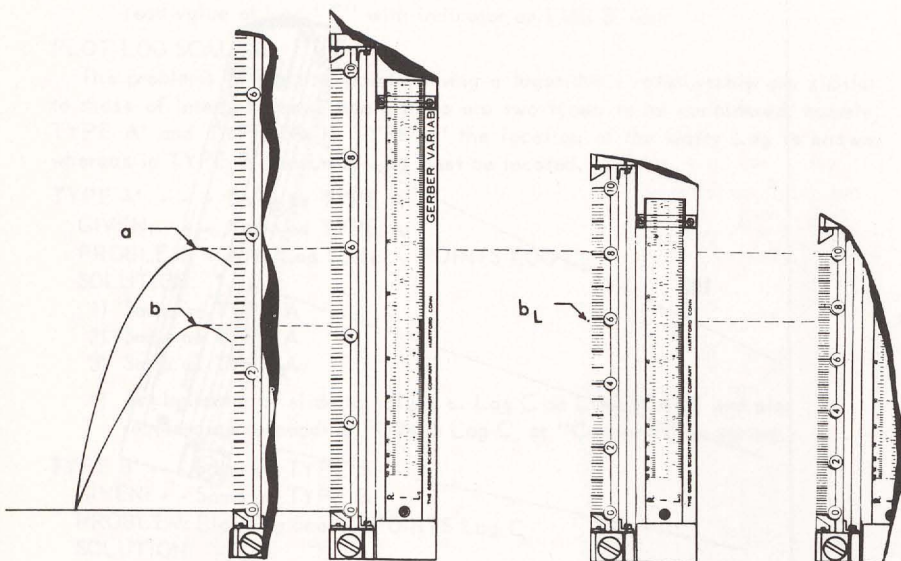

### PROBLEM:

The peak of curve "a" = 3.78. If  $a^n = b$ , find  $n$ .

### SOLUTION:

Place the 0 coil at the zero reference line and the 37.8 coil at "a", and read the peak of "b" = 26.9. Set the hairline at 3.78 on  $\text{Log}_{10}$  scale and read the "Constant" at "a" = 59.8. Move the hairline to 26.9 on the  $\text{Log}_{10}$  scale and plot point "b<sub>L</sub>" at the "Constant" = 59.8. (The linear ratio of  $b_L/a$  is the power value of  $n$ .) Therefore set the 10 coil at "a" and read the ratio at "b" = .745.

## PART "C"

This section is taken from the Instruction Manual No. 368 of the Gerber Variable Scale

### REFERENCE TABLES

Tables on methods of multiplication and division are included to help the user in cases where the settings are not immediately apparent.

The steps involved in the multiplication or division of a length by a number depend on the magnitudes of the original and resulting lengths.

In the table for multiplication, in three cases, a choice of methods is given; the first is quicker, and the second more accurate.

For a length between 1 and 10 inches multiplied by a number between 1 and 10, the first method given is applicable if the resulting length is less than 10 inches. If the resulting length is more than 10 inches, the second method must be used.

In the table for division, there are alternate methods in each case. Only one method will work in a particular problem. It is suggested that the user try step 2 of the first method. If this step is impossible, use the alternate method.

In every case, for both multiplication and division, the first step is to set the 0 coil at the left of the length involved. In the table, the coils are considered to be numbered from 0 to 100, with the 10's red and the 5's green to facilitate reading. References to the "38.2" coil are not, of course, to an actual coil, but to a visual interpolation between the 38 and 39 coils.

The digits 3-8-2 have been chosen for illustration, but have no particular significance.

In the special case in which a length between .1" and 1" is to be divided by a number between .01 and .1, and the first method is impossible, steps 4 through 6 may need to be varied. If the resulting length is sufficiently short (less than 10"), the 10 coil instead of the 20 may be set in step 4, and the answer read at once on the 100 coil. In a very few instances, it will be necessary to set the 33.3 coil in step 4, and to lay off two times the 100 coil in step 6. This matter will be as obvious in using the instrument as it is obscure in reading it.

## MULTIPLICATION

NOTE: In all cases Step 1 is: Set 0 coil at left of length

	To Multiply By .01 to .1 Say .0382	To Multiply By .1 to 1 Say .382
If Length is .01 to 1 in.		2. Set 1 coil at rt. of length 3. Mark at 38.2 coil 4. Set 100 coil at mark 5. Answer at 1 coil
If Length is .1 to 1 in.	2. Set 10 coil at rt. of length 3. Mark at 38.2 coil 4. Set 100 coil at mark 5. Answer at 1 coil	2. Set 10 coil at rt. of length 3. Answer at 3.8 coil  2. Set 10 coil at rt. of length 3. Mark at 38.2 coil 4. Set 100 (or 10) coil at mark 5. Answer at 10 (or 1) coil
If Length is 1 to 10 in.	2. Set 100 coil at rt. of length 3. Answer at 3.8 coil  2. Set 100 coil at rt. of length 3. Mark at 38.2 coil 4. Set 100 (or 10) coil at mark 5. Answer at 10 (or 1) coil	2. Set 100 coil at rt. of length 3. Answer at 38.2 coil

<p>To Multiply By 1 to 10</p> <p>Say 3.82</p>	<p>To Multiply By 10 to 100</p> <p>Say 38.2</p>
<p>2. Set 1 coil at rt. of length 3. Answer at 3.8 coil</p> <p>2. Set 1 coil at rt. of length 3. Mark at 38.2 coil 4. Set 100 coil at mark 5. Answer at 10 coil</p>	<p>2. Set 1 coil at rt. of length 3. Answer at 38.2 coil</p>
<p>2. Set 10 coil at rt. of length 3. Answer at 38.2 coil</p>	<p>2. Set 10 coil at rt. of length 3. Mark at 38.2 coil 4. Set 10 coil at mark 5. Answer at 100 coil (For distance less than .382 inches)</p>
<p>2. Set 100 coil at rt. of length 3. Mark at 38.2 coil 4. Set 10 coil at mark 5. Answer at 100 coil</p> <p>or</p> <p>2. Set 100 coil at rt. of length 3. Set 0 coil at rt. of length and lay off required No. of digits (in this case 3) 4. Set 0 coil at last mark 5. Answer at 82 coil</p>	

DIVISION

	To Divide By .01 to .1 Say .0382	To Divide By .1 to 1 Say .382
If Length is .01 to .1 in.	<p>2. Set 3.8 coil at rt. of length 3. Answer at 100 coil</p> <p>2. Set 1 coil at rt. of length 3. Mark at 10 coil 4. Set 38 coil at mark 5. Answer at 10 coil</p>	<p>2. Set 3.8 coil at rt. of length 3. Answer at 10 coil</p> <p>2. Set 1 coil at rt. of length 3. Mark at 10 coil 4. Set 38.2 coil at mark 5. Answer at 10 coil</p> <p>2. Set 1 coil at rt. of length 3. Mark at 100 coil 4. Set 38.2 coil at mark 5. Answer at 1 coil</p>
If Length is .1 to 1 in.	<p>2. Set 3.8 coil at rt. of length 3. Answer at 100 coil</p> <p>2. Set 38.2 coil at rt. of length 3. Mark at 100 coil 4. Set 20 coil at mark 5. Mark at 100 coil 6. Slide 0 coil to 2nd mark 7. Answer at 100 coil</p>	<p>2. Set 38.2 coil at rt. of length 3. Answer at 100 coil</p> <p>2. Set 10 coil at rt. of length 3. Mark at 100 coil 4. Set 38.2 coil at mark 5. Answer at 10 coil</p>
If Length is 1 to 10 in.		<p>2. Set 38.2 coil at rt. of length 3. Answer at 100 coil</p> <p>2. Set 100 coil at rt. of length 3. Mark at 10 coil 4. Set 38.2 coil at mark 5. Mark at 100 coil 6. Set 20 coil at mark 7. Mark at 100 coil 8. Slide 0 coil to 2nd mark 9. Answer at 100 coil</p>



<p>To Divide By 1 to 10 Say 3.82</p>	
<p>2. Set 38.2 coil at rt. of length 3. Answer at 10 coil</p> <p>2. Set 3.82 coil at rt. of length 3. Answer at 1 coil</p> <p>2. Set 10 coil at rt. of length 3. Mark at 100 coil 4. Set 38.2 coil at mark 5. Answer at 1 coil</p>	
<p>2. Set 38.2 coil at rt. of length 3. Answer at 10 coil</p> <p>2. Set 100 coil on rt. of length 3. Mark at 10 coil 4. Set 38.2 coil at mark 5. Answer at 100 coil</p>	