

SVENSKA  
HYDROGRAFISK-BIOLOGISKA KOMMISSIONENS  
SKRIFTER

TREDJE SERIEN: HYDROGRAFI. BAND 1. HÄFTE 2.

---

# THE PISTON CORE SAMPLER

BY

B. KULLENBERG



X B 1/1

**RB**

**10399**

**K96**

GÖTEBORG 1947  
ELANDERS BOKTRYCKERI AKTIEBOLAG

## P R E F A C E   A N D   A C K N O W L E D G E M E N T S

The new coring instrument described in this paper was developed during the war years. According to a suggestion by HANS PETTERSSON he and the present author tried to develop a hydraulic coring instrument which was to be forced down into the sediment by the hydrostatic pressure at the bottom of the sea. Failing in this we developed a gravity core sampler where according to a suggestion by the present author the sediment was to be forced into the coring tube by the hydrostatic pressure. Not succeeding to obtain sufficiently undisturbed cores in this way the present author searched for other methods. It proved possible to modify the so called piston borer used by geotechnicians for ground investigations so as to get a free-fall gravity core sampler, the piston core sampler, able to take home long and nearly undisturbed cores from the sea bottom.

The new apparatus was not considered finally tested until the end of the war made it possible to try it in deep water during a cruise on board the Swedish research ship *Skagerak* in the Mediterranean in the spring of 1946. This is the reason why no detailed account of the piston core sampler was given at an earlier date.

I am under great obligation to Professor HANS PETTERSSON, who aroused my interest in deep-sea coring and has allowed me the privilege of many valuable discussions on the subject. He has supported the work with a never failing enthusiasm and a firm belief in its final success.

My cordial thanks are due to the State Geologist Dr CARL CALDENIUS for his most valuable and helpful suggestions.

I am very much indebted to my friends and co-workers of many years standing, Mr AXEL JONASSON, who constructed the coring instruments and suggested many important improvements during our numerous discussions, and Mr AUGUST NILSSON, whose fifty years seamanship made him the right man to organize the operation of the unwieldy gears on board.

My sincere thanks are due to the *Naval Authorities in Gothen-*

*burg* as well as to the late Hydrographer, Commodore GUNNAR BLIX, to whose courtesy I owe the permission to make experiments from on board H. M. ships, which greatly facilitated my work during the war.

Gothenburg, December, 1946.

*B. Kullenberg.*

## INTRODUCTION

The core samplers used by the great expeditions during this century are mainly modifications of the apparatus designed by F. L. EKMAN (1). The first improvements were introduced by V. W. EKMAN (2), whose core sampler was able to take home nearly 180 cm long cores from soft bottom, though as a rule the cores did not exceed one metre. The inside diameter of the collecting tube was then about 40 mm. This apparatus, slightly modified by O. PRATJE (15), was used during the «Meteor» expedition. Its inside diameter was cut down to 20 mm, which seems to be the main cause that the cores obtained during the «Meteor» expedition never exceeded one metre, the average length being about 45 cm. PH. H. KUENEN (6, 19) increased the dimensions of the apparatus, giving it a length of 4 m and an inside diameter of 45 mm. This instrument was used during the «Snellius» expedition and proved capable of obtaining more than 2 m long cores.

It is an old experience that the EKMAN sampler will not be filled with sediment up to the point to which it has penetrated into the bottom. This is due to the friction between the sediment and the walls of the collecting tube and, possibly, to some extent to the pressure exercised by the water in the tube. The pressure is dependent on the shape and dimensions of the valve at the top of the tube as well as on the velocity of the tube, and it is apt to cause trouble if the bottom is very soft. In the PIGGOT sampler the design of the top valve was a question of vital importance, as the high velocity would give rise to a correspondingly high pressure within the tube, which made the water behave almost as a solid body until an adequate water exit port had been constructed.

The complications due to friction between the sediment and the inner walls of the collecting tube have been studied by O. PRATJE (16, 17), K. O. EMERY and R. S. DIETZ (3), and others. PRATJE found the top layer of the sediment column to be fairly correctly represented by the core. Very soon, however, the friction will



Fig. 1. The  
EKMAN sampler  
as modified by  
O. PRATJE.

offer resistance to the sediment about to enter the tube. As a consequence, the sediment that has already entered the tube will exercise a pressure on the layers just below the mouth of the tube. These layers will yield to the pressure, and so only part of them will enter the tube, the rest slipping away. Each layer will be thinner in the core than in the sediment column *in situ*. The effect will increase according as the core is lengthened when the tube penetrates deeper into the bottom. Finally, the pressure called forth by friction will be high enough to prevent any more sediment from entering the tube. Then the core will have reached its maximum length, irrespective of the further penetration of the sampler into the bottom — provided the sampler does not strike harder sediment further down. Actually, when no more sediment enters the tube, then the pressure exercised *on the core* by the sediment below the mouth-piece, «the outside pressure», will be equal to the pressure exercised by the core on the sediment below the mouth-piece. If, later, the core sampler should reach down to a harder layer, then the outside pressure would again exceed the inside pressure, and some new sediment would enter the sampler. When the sediment column contains alternating soft and hard layers, which is very often the case, it may occur that the outside pressure will exceed the inside pressure when the core sampler is penetrating the hard layers, whereas it will be less than the inside pressure when the sampler is penetrating the soft layers. Then the hard layers will be represented in the core, though they will be thinner than *in situ*, but the soft layers will not occur at all in the core.

In order to diminish the friction on the inner walls of the collecting tube, PRATJE made the inside diameter of the mouth-piece a little smaller than that of the tube. This met with great success, and although he did not obtain cores as long as the depth of penetration their length was sometimes almost doubled. He also found celluloid to be a more suitable material than glass for the lining tubes.

The disturbance caused by friction will be smaller the larger the inside diameter of the collecting tube. In fact, the pressure exercised

by the core on the sediment immediately below the entrance of the tube will amount to  $F : q$  dyn/cm<sup>2</sup>,  $F$  dyn being the friction on the walls of the tube, and  $q$  cm<sup>2</sup> being the inside square section of the tube. The friction is proportionate to the inside diameter of the tube, and so the pressure will be proportionate to the inverse of the inner diameter. Therefore, in a fairly homogeneous sediment the length of the cores should be about proportionate to the inside diameter of the collecting tube. This will explain why KUENEN was able to obtain cores more than double as long as those obtained by PRATJE and CORRENS during the »Meteor» expedition. As stated above, the inside diameter of KUENEN's core sampler was 45 mm, as compared with 20 mm in the Meteor sampler. Of course, the diameter of the tube should not be increased above a certain limit, presumably about 50 mm, as the coherence of the core would then easily be overstrained and the core become distorted.

The core sampler of C. S. PIGGOT (13) marked a great progress in the technique of deep-sea coring, as it was able to obtain 3 m long cores from the ocean bottom. This must be due to the high velocity of the coring tube when it is going down into the bottom. The velocity will not affect the friction between the sediment and the inner walls of the tube very much, and the friction will not be so great as to give the sediment the acceleration necessary for it to escape the core sampler. As to the pressure exercised on the core from below, this will be dependent on the velocity of *the core*, not on that of the tube. The core will have attained its maximum length when the outside pressure is balanced by the friction. Then the core will have the same speed as the tube, and at this high velocity (though lower, of course, than the initial velocity) the outside pressure will be very high — like the pressure on a flat piece moving in a liquid perpendicular to itself, which will increase very much with the velocity. The friction on the inner walls being correspondingly great, the core length must have been increased as compared with the one obtained when the velocity is smaller.

The diminution of the effect of friction through the high velocity and the provision of an adequate water exit port are the essential features of the PIGGOT sampler, whereas even in a rather hard bottom the same penetration depth could be obtained by the mere weight of the apparatus without any use of explosives.

PIGGOT has later carried out an investigation of the thinning out of the layers with a view to making it possible to estimate the thickness *in situ* of the layers found in a core (14).

## THE VACUUM CORE SAMPLER

The idea of making use of the hydrostatic pressure at the bottom of the sea in order to obtain long sediment cores was first advanced by J. JOLY (5), though the apparatus designed by him was never brought to a test. Another »Hydraulic coring instrument» was developed by F. M. VARNEY and L. E. REDWINE (18), who used the hydrostatic pressure to drive a coring tube down into the bottom.

In 1933 Professor HANS PETTERSSON suggested to the present author that the hydrostatic pressure at the bottom of the sea might be used to force a coring tube down into the bottom. The idea was that an evacuated tube should be sent down to the bottom, the tube being permanently shut at the top end and being shut by a valve at the lower end. The valve was to be contrived in such a way as to lay open the entrance of the tube at the moment the tube struck the bottom. It was assumed that the hydrostatic pressure would then force the tube down into the bottom, the pressure resting only on the top of the tube.

Other work made it impossible to take up the problem for many years. Not knowing that VARNEY and REDWINE had already tried a similar scheme, we put it to a test in 1939. The very first experiments proved that the idea did not work if carried out in the simple manner stated above. They made us realize, however, that the hydrostatic pressure could be used in quite another way, namely to overcome the friction between the core and the coring tube.

This was carried out in the following way (8, 11, 12). The coring tube was attached to a strong spherical container at its top end. The communication between the tube and the container was shut off by a valve able to withstand a very high pressure, whereas the tube was open at its lower end. Before the apparatus was sent down the container was evacuated, and the apparatus was loaded with iron weights intended to force the tube into the bottom. The weight of the apparatus could be increased to 1000 kg, which proved sufficient to drive a coring tube with 80 mm outside diameter down 17 m into

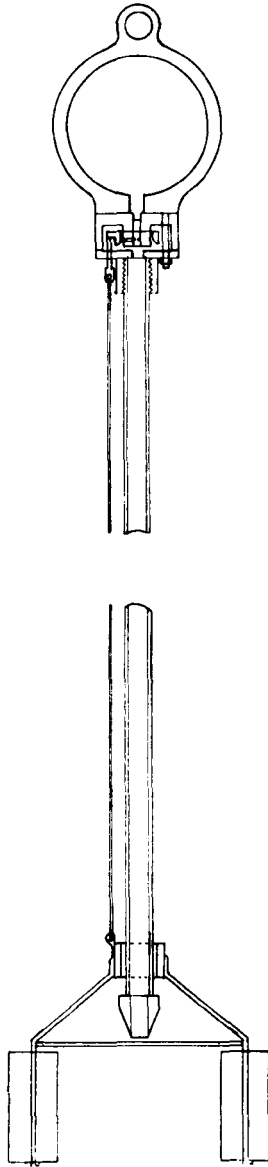

Fig. 2. The vacuum core sampler.

the comparatively loose bottom in the northern part of the Skagerack. The core sampler was then lowered at the rate of 3.5 m/sec.

Immediately before the mouth of the tube impinged on the bottom, the valve opened automatically, and then the water in the tube was pressed into the container. However, the entrance of the water into the vacuum container was obstructed by a circular metal plate at the top of the tube with only a small opening in it. The depth being known, it is possible to calculate the rate at which the water will stream into the container. The sediment, unable to resist the great hydrostatic pressure, must enter the collecting tube at the same rate. This being known, it remains to lower the apparatus at a corresponding velocity, so that the core sampler will go down into the sediment with the same velocity at which the sediment is being pressed into the tube. The throttle-valve at the top of the tube being interchangeable, it is always possible to obtain a suitable lowering velocity.

The core sampler will keep a constant velocity until shortly before it reaches its penetration depth, provided, of course, the rope is being lowered at a constant speed. In fact, as long as the resistance raised by the sediment to the penetration of the apparatus does not exceed the weight of the apparatus in water, the velocity will not decrease. As soon as the resistance has exceeded the weight of the sampler, the motion will be retarded, and the sampler will come to a standstill very soon, as the initial velocity is not very high.

The friction between the sediment and the inner walls of the coring tube will diminish the water pressure inside the tube according as the core length increases, and this will affect the course of events



at moderate depths. Because of the diminished pressure the water in the tube will flow slower and slower into the vacuum container, and as a consequence the sediment will not enter the tube in the same proportion as the tube penetrates into the bottom. There will be a thinning out of the deeper layers, the degree of which it is possible to calculate, however. To give an idea of the magnitude I may state that, if the depth is 100 m, the deepest layers in a 10 m long core will have a thickness about 60 % of the thickness of the corresponding layers *in situ*.

At a great depth the friction will be small as compared with the water pressure, and then it will not affect the core perceptibly. However, the technical difficulties will increase considerably at great depths.

## THE PISTON CORE SAMPLER

The piston core sampler (7, 8) has been based on a method to procure samples for ground investigations, developed by the Geotechnical Department of the Swedish State Railways, the instigators being C. CALDENIUS and J. OLSSON (9).

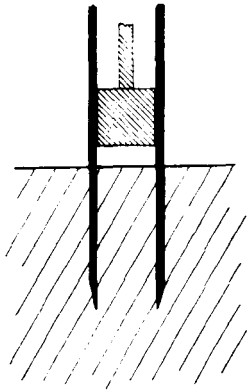

Fig. 3. Principle of the piston core sampler.

The method should be clear from Fig. 3, showing a tube being forced into the sea bottom. Inside the tube there is a closely fitting piston, which is being kept immobilized immediately above the bottom. As the tube is going down, the friction will exercise a downward pull on the core, which is opposed, however, by the hydrostatic pressure on the bottom. The hydrostatic pressure will not allow a vacuum to be created between the piston and the top of the core so long as the frictional forces do not exceed the hydrostatic pressure. This will never be the case in a deep sea, but it may happen in shallow water. This will be discussed later. However, when the tube is penetrating the bottom, the friction will always cause the pressure immediately below the piston to be diminished as compared with the hydrostatic pressure. The pressure difference between the mouth of the tube and the top of the core will automatically balance the frictional resistance to the core, which, therefore, will be a quite correct representation of the sediment column *in situ*. The one problem is the immobilization of the piston in the vicinity of the bottom.

### BRIEF DESCRIPTION OF THE PISTON CORE SAMPLER

For the sake of perspicuity a brief description of the piston core sampler will be submitted as a preliminary to a detailed account. The denotations refer to Fig. 4.

A thick steel tube *a*, the length of which may be 20 m or even more, is loaded with heavy weights *g* corresponding to the length of the tube and the consistency of the sediment. The tube is suspended from the release mechanism *h*, the most prominent part of which is the lever, one arm of which is about 15 times as long as the other. The tube is suspended from the short arm and is balanced by a counter-weight *n* suspended from the long arm, the counter-weight having about one tenth the weight of the rest of the core sampler. The tube is suspended in such manner that it will slip off the release mechanism if the counter-weight is put out of function in some way or other. The release mechanism is furnished with an eye for the steel cable that serves to lower the core sampler to the bottom of the sea. The counter-weight is suspended from a rope so as to hang at least one metre below the mouth of the tube. It is attached to the tube in a manner permitting it to move up and down the latter.

The steel tube is lined inside with brass tubing. In the lower end of the tube there is a piston *m*, which fits closely within the brass

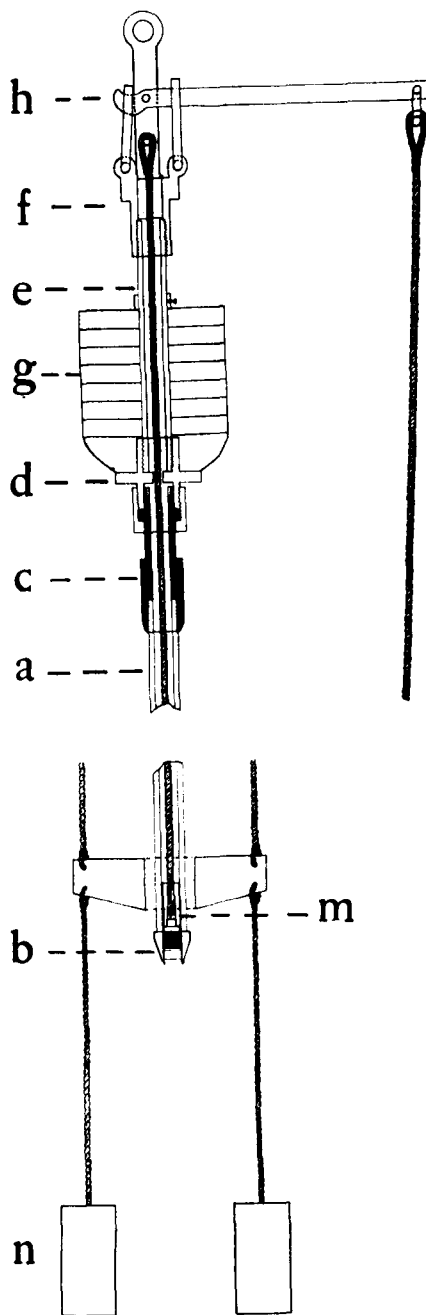

Fig. 4. The piston core sampler.

tube and is able to move in this. The piston is connected with the release mechanism by a steel rope that runs up through the tube.

When the core sampler is approaching the bottom, the counterweight will strike the bottom first, unloading the lever in doing so. Then the tube will slip off and drop into the sediment in a vertical position at a rather high velocity. The diminished tension of the cable will be announced on board the ship by a dynamometer, whereupon the winch is stopped, the piston being thereby brought to a stop just above the bottom. Now the sediment is forced to enter the tube, otherwise a vacuum is created in the tube below the piston. No matter how deep the tube penetrates the bottom the length of the core will be equal to the penetration depth, provided the water is not too shallow. The weight of the core sampler corresponding to a given penetration depth will be diminished by the fact that the apparatus is allowed to drop into the mud unhindered by the cable.

In its lower end, immediately above the mouth-piece *b*, the tube is provided with a core catcher intended to prevent the core from slipping out of the tube when the core sampler is being hauled up through the water.

#### DETAILED DESCRIPTION OF THE PISTON CORE SAMPLER

*The Coring Tube* is a cold drawn steel tube with an internal diameter of 52 mm and a wall thickness of 14 mm. As it will be exposed to great bending stresses when being forced down into a hard bottom, a rather hard steel has been selected. On the other hand the steel must not be brittle, as the tube would then be liable to break during the operations necessary to put the core sampler into the sea or to take it on board.

The tube may be given a length of 20 m or even more, but it will not always be convenient to keep it as long as that. As the maximum length of the tube should depend on the penetration depth in a soft bottom, provided the space on board does not set a limit, it will not be possible to make the tube penetrate to its maximum length in a hard bottom. Then it is advisable to adjust the length of the coring tube according to the obtainable core length. In shallow water the core length will not exceed a certain value, irrespective of the penetration depth. Occasionally it may occur that the sediment is considerably less than 20 m in thickness, in which case the tube may be bent on striking the hard material below the sedi-

ment. If the tube were manufactured in one single piece, it would then be completely destroyed, but if shorter tubes have been screwed together, only one of the short tubes will be destroyed.

Therefore the tube is composed of about 5 m long pieces, which are screwed together. The joints will of course be weaker than the rest of the tube, which, however, has proved fatal only once. On that occasion a more than 20 m long tube had stuck fast in the bottom, possibly being jammed between stones, and then the tube broke at a joint after very violent pulling, and 15 m of the coring tube was lost. Though it has occurred in a few instances that the tube has been bent when striking hard material, the bend has never been localized to a joint.

The cold drawn steel tubes have been delivered by the Sandvik Steel Works Co., Ltd., Sandviken, Sweden.

*The Mouth-Piece* (Fig. 5) has a maximum external diameter which is 10—15 mm larger than that of the coring tube. There are two reasons for this. Firstly, the friction on the outside walls of the tube will be diminished by the water descending in the wake of the mouth-piece. Possibly the force necessary to pull the sampler out of the bottom will diminish also. KUENEN (6, 19) has found that to be the case with a 4 m long tube, but I have not been able to decide whether it is the case with a longer tube. Secondly, for the functioning of a core catcher installed immediately above the mouth-piece and intended to prevent the core from falling out of the tube, it is essential that the mouth-piece itself should be held back by the sediment with some force when the sampler is being pulled out of the bottom.

The internal diameter of the undermost part of the mouth-piece is about 1 mm smaller than that of the lining tubes. This is intended to diminish the friction between the sediment and the inner walls of the tube; the device was introduced by PRATJE, as stated above. In the piston core sampler it is not necessary to diminish the friction in order to get long cores, as the friction is eliminated by the hydrostatic pressure. However, the friction will exercise a force on the peripheral parts of the core and, therefore, will be apt to bend the sediment layers. Hence it is essential to diminish the friction as much as possible.

The mouth-piece is lined with a brass tube that fits so tightly as to adhere to the inner walls of the mouth-piece.

The *Core Catcher* is installed in the upper part of the mouth-piece. It consists of a metal sheet that is shaped so as to form a part of a cylindrical surface, the diameter of which is the same as that of the lining tubes and it is able to shut the lining tube completely. When open, the catcher forms a part of the lining tube. It is able to move about a horizontal axis at its lower end, the axis being tangential to the lining tube.

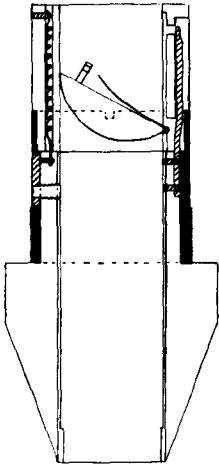

Fig. 5. The mouth-piece with the core catcher.

During the descent of the core sampler the core catcher is held fast in its position against the wall of the tube by a pin attached to the mouth-piece. Then the free access of the core into the tube is not obstructed. When the sampler is being pulled out of the bottom, however, the mouth-piece, sticking into the sediment thanks to its larger diameter, will be held back two or three millimetres, and then the pin will release the catcher. This will be pressed two or three millimetres into the core by a rather weak spring, and if the core does not move, nothing more will happen. That will generally be the case. If the core starts to slip out of the tube, however, the core itself will force the sediment catcher to seal the lining tube, and then only the small part of the core situated below the catcher will be lost. In the case of the long cores obtained with the piston core sampler only a very soft sediment will be apt to fall out of the tube, and so the core catcher need rarely go into action.

The *Lining Tube* is made up of 70 cm long brass tubes with 45.6 mm internal diameter and 1 mm wall thickness. It is necessary to have the lining tube made up of short pieces like this, because it would otherwise be difficult to take the sample out of it. At the top end the lining tube is supported by the coupling (Fig. 4 c and 8) and at the lower end it is kept in position by a frame as shown in Fig. 6. The mouth-piece is screwed until it is stopped by the frame, whereupon every lining tube piece rests against the adjoining pieces. Thus, the coupling and the mouth-piece will keep the lining-tube pieces together longitudinally, and furthermore the adjoining tubes are kept together by short collars as shown in Fig. 7. The space

between the collars and the steel tube being very small, the lining tube is well supported.

The brass tubes should be carefully selected, as the diameter must be exactly the same everywhere. No ovalness must be allowed, as otherwise the piston may dash against some projection at a tube joint and utterly ruin every brass tube in its way. That has happened once during my experiments.

The lining tube will be exposed to a certain amount of pressure when the core sampler is going down into the sediment and, sometimes, especially much when the sampler is being pulled out of the bottom. If, for instance, the penetration depth is smaller than the length of the coring tube, then the piston will be at a certain distance below the top of the collecting tube when the core sampler has stopped. As soon as hauling begins, the pressure below the piston will decrease considerably and that will go on until the piston is stopped at the top of the tube. This is due to the fact that the friction between the core and the walls of the tube will be much larger after the sampler has stopped than before. Further, a sucking in of sediment from below the mouth-piece will also make the pressure decrease. In most cases there will be no such sucking in, but the vacant space will be filled with water leaking in from the space between the lining tube and the coring tube. Water may leak in through any joint between adjoining brass tubes, and hence the core may be divided into several pieces, with water between them. This is a very unsatisfactory condition, and it should be avoided by always forcing the core sampler down into the bottom to its full length.



Fig. 7. Collar keeping adjoining pieces of the lining tube together.

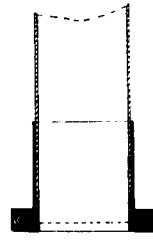

Fig. 6. Frame for the lining tube at the lower end.

However, it might occur that the pressure below the piston decreases so much as to make the lining tube collapse, which has happened three times. Obviously the strength of the brass tubes is only just sufficient to stand the strain, and so it might be better to exchange them for steel tubes. This would involve some risk of contaminating the sample, as steel would be much more affected than brass by water and sediment. That might be avoided by the use of stainless steel, though.

Another method would be to line the steel lining tube in its turn with brass tubes, split longitudinally into halves and fitting closely to the steel lining tubes. That would at the same time make it easier to take the sample out of the lining tube without disturbing it.

*The Coupling* is intended to facilitate the removing of the upper part of the core sampler from the collecting tube, which operation

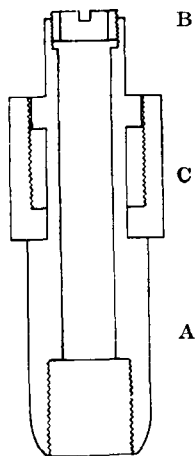

Fig. 8. The coupling.

has to be performed every time the core sampler has been employed. The coupling is made up of three pieces. The largest one (Fig. 8, A), being made of steel, has an axial bore with a diameter of 50 mm, except at the ends, which are wider and are provided with female screw-threads. At the lower end the bore has a diameter of 75 mm, and the screw-threads at this end are intended to fasten the coupling to the top of the coring tube. At the top end the bore has a diameter of 63 mm. The second piece of the coupling (Fig. 8, B) is fastened here. It is a brass ring with male screw-threads, the outside diameter being 63 mm, and the inside diameter being equal to that of the lining tube, *i. e.* 45.6 mm. At the top end of both pieces there are four square slits, about  $10 \times 10$  mm, as an extra outlet valve for the

water. The object of the brass ring is to support the top end of the lining tube. The third piece of the coupling (Fig. 8, C) is a steel ring with an inside rim at the lower end. There is an outside rim near the top end of the larger piece (A), and the steel ring (C) can only be moved until the two rims come together. The ring has an inside diameter of 110 mm, and it has female screw-threads intended to fasten the coupling to the upper part of the core sampler. It has four canals near its upper end, serving to let out the water. As the steel ring can be turned without moving the rest of the coupling, nothing but the steel ring has to be turned when the coring tube is to be fastened to, or unfastened from, the rest of the core sampler.

*The Weight-Stand* is a steel tube (Fig. 4 e) with a steel cylinder fastened to each end of it. The tube may be exchanged in order to adjust its length according to requirements. Its dimensions are the same as those of the coring tube, *i. e.* the outside diameter is 80 mm and the wall thickness 14 mm. It has male screw-threads at both ends.



The steel cylinder at the lower end (Fig. 4 *d*), «the connecting piece», has an outside diameter of 110 mm. It has an axial bore of 75 mm, which, halfway, is narrowed to a diameter of 30 mm. The interior rim thus obtained serves as a piston catch to stop the piston when the core sampler has gone down into the mud to its full length.

Externally a thick shelf runs round the middle part of the cylinder, serving to support the weights necessary to force the core sampler down into the bottom. Below the shelf the cylinder has male screw-threads corresponding to the female screw-threads in the steel ring of the coupling. Above the shelf it has female screw-threads serving to fasten it to the weight tube.

The cylinder at the top end of the weight tube (Fig. 4 *f*) has an axial bore 75 mm in diameter. At the lower part it has female screw-threads, serving to fasten it to the tube, whereas the bore is smooth in the upper part. At the top the cylinder is fitted with two loops opposite to each other. In one of the loops there is fastened a link as shown in Fig. 9 *a*, serving to suspend the bulk of the core sampler from the short arm of the lever. The link is able to turn round the bolt at its lower end, which is run through the loop. In the other loop there is fastened a safety link as shown in Fig. 9 *b*, serving to fix the lever in a position perpendicular to the tube. This will make it impossible for the tube to fall off the release mechanism accidentally during the operations necessary to put the core sampler into the sea. The safety link should not be removed until immediately before the lowering of the core sampler is to begin, when all preparations are completed and the sampler is hanging in the water in a vertical position.

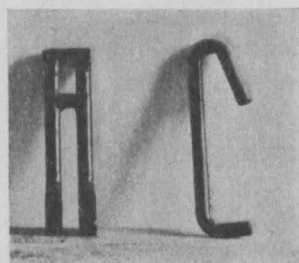

a b  
Fig. 9. Suspending link (a)  
and safety link (b).

*The Weights.* (Fig. 4 *g*). The undermost weight is a complete cylinder, rounded off at the lower end, and with a central bore for the tube. The other weights are semi-circular iron plates with a notch for the tube, each weighing 20 kg. Underneath, they are provided with two holes to receive pegs in the top of the subjacent plates. They are laid cross-wise over each other, two in each layer, being thus mutually fixed in their position by the pegs. Above the uppermost

layer a steel clamp is fixed to the tube with a screw, serving to prevent the weights from jumping off at occasional jerks. The arrangement now described has proved to be a convenient one when working the heavy gears on board a rolling ship.

*The Release Mechanism* (Fig. 10) consists of the lever and a stand for the latter. The lever is a wrought iron bar, 2 cm thick, 5 cm wide, and 85 cm long. It has a bore for the axle a few cm from one end, and another one near the other end, serving to suspend the counterweight.

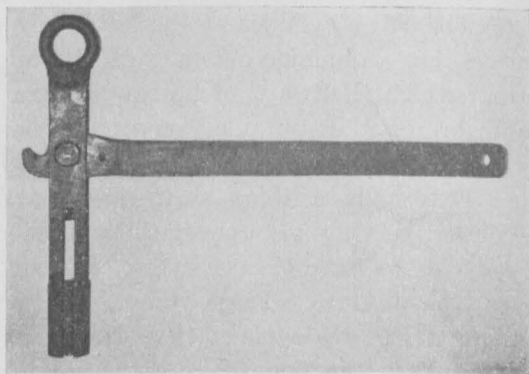

Fig. 10. The release mechanism.

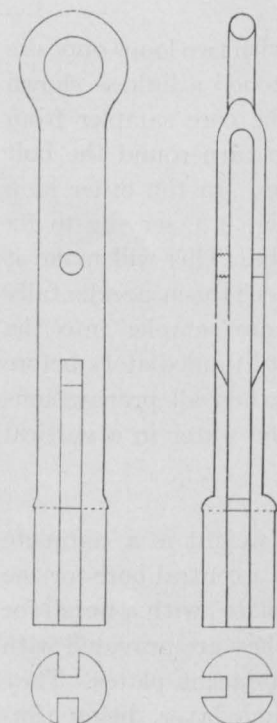

Fig. 11. The lever-stand.

The bulk of the core sampler is hung on the short arm in the link referred to before. The arm is 5 cm long, and it is shaped like a beak so as to make it easy for the suspending link to slip off as soon as the arm has been lowered to a sufficient extent. The other arm, which is depressed by the counterweight, is 70 cm long.

The lever-stand (Fig. 11) is made up of a short steel rod undermost and two wrought iron bars welded to the rod. At the uppermost end the bars are welded to a wrought iron ring to which the long sounding cable is fastened when the apparatus is to be lowered to the bottom of the sea. Halfway between the ring and the rod, both bars have a bore-hole for the bolt serving as an arbor for the lever.

The rod fits into the smooth bore of the cylinder which is fastened to the top of the weight tube. This is in order to fix the release mechanism in its proper position relative to the rest of the core

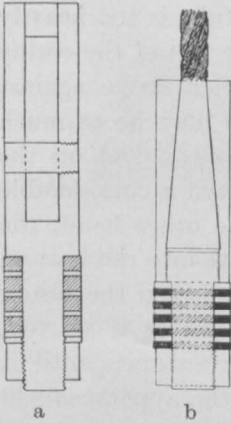

Fig. 12. The piston.

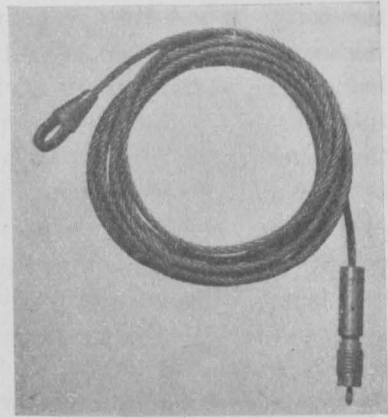

Fig. 13. The piston attached to the piston rope.

sampler. The rod has two slits opposite to each other, and the slits are extended in the bars half-way to the arbor of the lever. The object of the slits is to let out the rope that joins the piston to the release mechanism. Originally there was a second bolt through the bars for the purpose of fastening the piston rope, but that has turned out to be inconvenient. The present arrangement, in which the piston rope is fastened directly to the eye of the core sampler, may seem provisional, but it has proved to be very practical.

*The Piston* is shown in Fig. 12 in two slightly different patterns. In one of them (Fig. 12 *a*) the piston rope has a spliced loop, and it is fastened to the piston by means of a bolt through the loop. In the other pattern (Fig. 12 *b*) the rope is fused to the piston, which makes it possible to use a thicker rope than in the other method. The rope runs up through the tube, and it is fastened to the eye of the core sampler.

The bulk of the piston has a diameter that is 1 mm less than that of the brass lining, and only the packings fit closely in the lining tube. The packings consist of a series of circular leather clips with slightly smaller brass plates between them. In the centre they have holes for an axial bolt and they are fastened to the bolt with a firmly tightened nut. The bolt is furnished with screw-threads at its upper end corresponding to female threads in the top-piece of the piston.

As soon as the counterweight has settled down on the bottom

the coring tube with the heavy weight at its top will slip off the release mechanism and fall into the mud. If the tube is too heavily loaded, the piston will get a violent kick when the top of the coring tube has come down to the piston, which will then strike against the piston catch. As the weight of the apparatus may be as much as 1500 kg, this involves a hard strain on the piston and on the piston rope, especially as the core sampler may have a considerable velocity at the moment of the impact. If, on the other hand, the tube is not sufficiently loaded to be able to penetrate into the bottom to its full length, there will be no such collision between the piston and the catch. When the hoisting of the core sampler is started, the piston will go upwards with no perceptible resistance until it has reached the catch. Then the whole weight of the apparatus will rest on the piston, and to this will be added the force necessary to pull the core sampler out of the bottom, which in some circumstances may be very great. Hence the piston and the piston rope must of necessity be strong. If the piston pattern *a* is used, it is difficult to use a rope of more than 10 mm diameter, which is hardly sufficient when the sampler has its maximum weight and is sticking fast in the bottom. The piston pattern *b* should therefore be preferred.

*The Counterweight* consists of iron cylinders, suspended from an iron bar as shown in Fig. 4. Sometimes the bar was equipped with four legs for the iron cylinders. The bar is connected to the coring tube by means of an iron ring in the middle of it. In this manner the centre of gravity of the counterweight will be located to the axis of the coring tube, and the core sampler will keep an accurately vertical position when suspended from its eye. That would not have been the case if the counterweight had hung vertically below its loop in the lever. Then the coring tube would have formed a small angle to the vertical, and, as the core sampler is very top-heavy, that would have increased the risk of its being upset when slipping off the lever.

When the core sampler is going down into the mud, the iron bar supporting the counterweight will settle down on the bottom, and it will be connected with the tube through the ring all the while. When the core sampler is being hoisted, the bar will keep near the coupling.

During the operations of taking the core sampler on board it is a great convenience to be able to hoist the apparatus by the

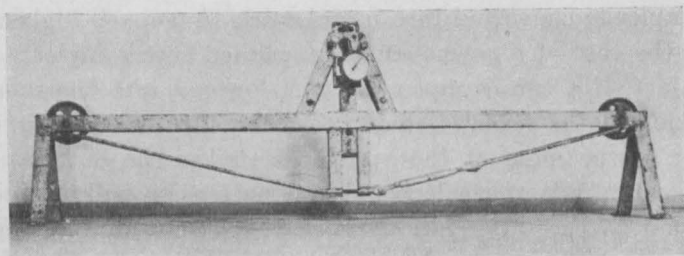

Fig. 14. The dynamometer.

counterweight rope, as the operations cannot be performed by means of the piston rope without this being sharply bent.

*The Dynamometer* is of the same pattern as the one used during the «Snellius» expedition (19). When core sampling at moderate depth, *i. e.* below 1000 m, we have used the small dynamometer shown in Fig. 14. It has two fixed pulleys at a distance of 200 cm from each other, and half-way between them there is a movable pulley lifting the cable up 10 cm. Above the movable pulley there is a stationary cylinder filled with oil in which a piston moves, and the pulley is suspended from the piston. A gauge shows the pressure in the cylinder, and the tension in the cable may be computed by multiplying the readings by a certain number. When working at great depth we have used a larger apparatus. As the most important object of the dynamometer is to announce the sudden relaxation in tension when the core sampler has reached the bottom, it has not been considered adequate to introduce a throttle valve.

#### ON THE THEORY OF THE FREE-FALL CORE SAMPLER

Thanks to the fact that when liberated by the release mechanism the piston core sampler is free to fall into the sediment without being hindered by the cable it is possible to diminish the drive weight of the apparatus as compared with a core sampler that is being lowered into the mud.<sup>1)</sup> This is because the potential energy of the free-fall

<sup>1)</sup> A free-fall coring tube fitted with a similar release mechanism as the one described here and in my papers of 1944 and 1945 has been developed by M. J. HVORSLEV and H. C. STETSON (4).

core sampler is converted into useful work to a much higher degree than in the case of a permanently suspended core sampler.

In fact, if a core sampler is being lowered into the mud, then the tension of the cable is equal to the weight of the core sampler in water at the moment the apparatus strikes the bottom, and as the core sampler is going deeper down the tension will diminish and keep equal to the difference between the weight of the apparatus (in water) and the resistance raised by the sediment. Therefore the potential energy of the core sampler is divided into two parts, one being wasted on useless work carried out on the sounding cable, and the other being converted into useful work overcoming the resistance of the sediment. From the moment the resistance of the sediment is equal to the weight of the core sampler (in water) the tension in the cable is zero, and now the further penetration of the tube is dependent on the kinetic energy of the core sampler, which will have kept constant until this moment. The kinetic energy corresponding to the relatively small speed of lowering will not be able to keep up the motion for long.

Obviously it depends on the character of the sediment how large a percentage of the potential energy is converted into useful work. The resistance being a function  $R(x)$  of the depth of penetration  $x$ , the amount of useful work  $A$  will be

$$A = \int_0^{x_0} R(x) dx,$$

$x_0$  being the depth at which the resistance is equal to the weight of the core sampler in water:  $R(x_0) = mg(1-1/d)$ ,  $m$  and  $d$  being the weight and the mean specific gravity of the core sampler, and  $g$  being the acceleration due to gravity.

Supposing the resistance be proportionate to the penetration depth, then

$$R(x) = mg(1-1/d) \frac{x}{x_0},$$

$$A = \frac{1}{2} mg(1-1/d) x_0,$$

whereas the potential energy consumed amounts to

$$P = mg(1-1/d) x_0.$$

During the continued motion from  $x_0$  to the maximum penetration depth the potential energy will be completely converted into useful work, as the tension of the rope is zero. So in this case only slightly more than 50 % of the potential energy will be converted into useful work. As a rule, however, the resistance of the sediment will rise more than proportionately to the depth of penetration. Then the amount of useful work will be still smaller; in case the resistance should rise proportionately to the square of the depth of penetration we have  $A = 1/3 P$ . So we may reckon that less than 50 % of the potential energy available will be made useful when an ordinary gravity core sampler is being lowered into the sediment.<sup>1)</sup> As to the kinetic energy, this is completely converted into useful work provided the unreeling speed is not too high for the extra resistance due to motion to be disregarded.

Now let us consider the free-fall coring tube. Firstly, it is possible to give the apparatus a high initial velocity by releasing it at an adequate height above the bottom. When this is to be done, it is necessary to give the piston rope a corresponding amount of slack, coiling it and securing adjacent coils by light twine in order to prevent kinking. Secondly, a high percentage of the potential energy available at the moment the core sampler strikes the bottom will be converted into useful work, as that part of it which is not consumed in overcoming the resistance of the sediment and the water will be converted into kinetic energy. Therefore the velocity of the core sampler will rise until the sum of the resistance raised by the sediment and the water drag is equal to the weight of the core sampler in water, and thanks to the increased kinetic energy the tube will be able to penetrate to a considerably greater depth.

The equation of motion of the piston core sampler when it is going down into the bottom is

$$m \frac{d^2x}{dt^2} = mg \left( 1 - \frac{1}{d} \right) - k \left( \frac{dx}{dt} \right)^2 - R(x),$$

$k(dx/dt)^2$  being the sum of the drag of the core sampler and the pressure exercised on the core sampler by the water within the coring

---

<sup>1)</sup> This seems to have been disregarded by HVORSLEV and STETSON (4), who consider the potential energy to be completely consumed in overcoming the resistance of the sediment. They have further left the buoyancy of the water out of account when calculating the velocity of the free-fall coring tube. Therefore the computed velocities are about 7 % too high.

tube. Putting  $(dx/dt)^2 = v^2 = y$ , we may write the equation as follows

$$\frac{dy}{dx} = 2g \left(1 - \frac{1}{d}\right) - \frac{2ky}{m} - \frac{2}{m} \cdot R(x).$$

$v$  denoting the velocity of the core sampler at the depth  $x$ , and  $v_0$  denoting the initial velocity, we get the following expression

$$v^2 = v_0^2 \cdot e^{-\frac{2kx}{m}} + \frac{mg}{k} \left(1 - \frac{1}{d}\right) \left(1 - e^{-\frac{2kx}{m}}\right) - \frac{2}{m} e^{-\frac{2kx}{m}} \int_0^x R(x) e^{\frac{2kx}{m}} dx.$$

Putting  $v = 0$ , the penetration depth can be determined by successive approximation, provided  $v_0$ ,  $k$ , and  $R(x)$  are known.

In case the resistance of the sediment is proportionate to the penetration depth, that is  $R(x) = rx$ , then we get the following expression

$$v^2 = \left[ v_0^2 - \frac{mg}{k} \left(1 - \frac{1}{d}\right) - \frac{mr}{2k^2} \right] e^{-\frac{2kx}{m}} + \frac{mg}{k} \left(1 - \frac{1}{d}\right) + \frac{mr}{2k^2} - \frac{rx}{k}.$$

In order to get an idea of the advantage derived by the free fall we will consider a numerical example. We assume  $r = 1.2 \times 10^6$  dyn/cm, *i. e.* 122 kg/m, which is about the »specific resistance» of the sediment off the Algerian coast if the outside diameter of the coring tube is 80 mm. The value of  $k$  is dependent on the dimensions and form of the apparatus as well as of the water exit port; we assume  $k = 400$  g/cm. Further we put  $d = 8$  g/cm<sup>3</sup>.

For the ordinary gravity core sampler the depth of penetration is determined as

$$x = \frac{mg}{r} \left(1 - \frac{1}{d}\right) + v_0 \sqrt{\frac{m}{r}}.$$

The result of the computations are given in Fig. 15, the graphs representing the depth of penetration for each core sampler as a function of the drive weight of the apparatus at different unreeling speeds for the ordinary gravity core sampler and at different initial velocities for the piston core sampler.

Taking an ordinary gravity core sampler weighing 1000 kg, the depth of penetration at an unreeling speed of 100 cm/sec will be 8.0 m. An equally heavy piston core sampler will obtain a depth



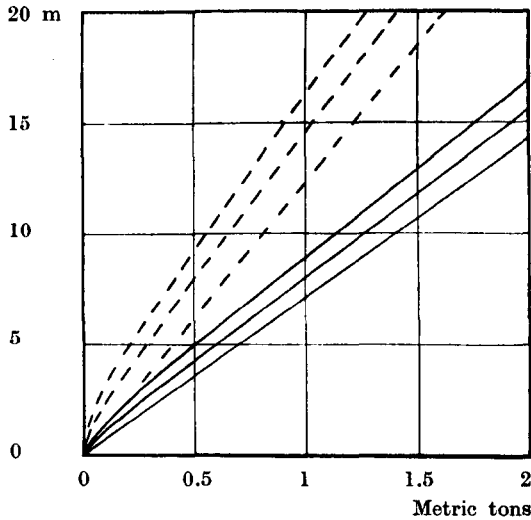

Fig. 15. Diagram showing the depth of penetration as a function of the drive weight. Full-drawn lines refer to an ordinary gravity core sampler (unreeling speed 0, 100, and 200 cm/sec), and dashed lines refer to the piston core sampler (velocity in the moment of impact against the bottom 0, 10, and 15 m/sec).

of penetration of 12.3 m if released immediately above the bottom, and 14.6 m if released about 6 m above the bottom. On the other hand, to obtain a depth of penetration of 15 m an ordinary gravity core sampler lowered at a velocity of 100 cm/sec should have a weight of 1920 kg, whereas a piston core sampler if released immediately above the bottom will require 1200 kg for the same depth of penetration and 1020 kg if released about 6 m above the bottom. Of course the counterweight will increase the total weight of the piston core sampler with about 10 %.

#### THE ELASTIC VIBRATIONS OF THE SOUNDING CABLE

If the core obtained by the piston core sampler is to be an exact reproduction of the sediment column *in situ*, it is necessary for the piston to be immobilized when the coring tube is going down into the sediment. However, the core will not be very much affected by movements of the piston when the speed of the latter is small compared with that of the falling coring tube. Thus, the vertical movements of the ship should not be considered a very serious drawback, especially as the heavy piston core sampler cannot be managed in

bad weather. Moreover, the water friction on the long cable will smooth the movements of the lower parts of the cable.

In this paragraph we will consider more closely some other circumstances influencing the movements of the piston, namely the longitudinal elastic vibrations of the sounding cable. Such vibrations will be started at the moment the core sampler falls off the release mechanism, and at the moment the lowering of the cable is stopped. Both systems of vibrations will affect the piston. In fact, as soon as the cable has been freed from the weight of the core sampler it will shorten itself, and as a consequence the piston will be pulled upwards. Further, when the lowering of a long cable is suddenly stopped, the lower end of the cable will not stop at all but will run up and down at the initial velocity, and with a periodity determined by the elastic properties of the cable.

The mathematical treatment of the problem will be found in textbooks of mathematical physics (See for example: A. G. WEBSTER, *Partial Differential Equations of Mathematical Physics*, New York, 1933). However, the results will be easily understood without acquaintance with the mathematical treatment. For the sake of perspicuity we will first treat each case separately.

*Elastic Vibrations generated when the Cable is being released from the Weight of the Core Sampler* — The tension in the cable is in the first place produced by the weight of the cable itself and in the second place by the weight suspended at the lower end, accelerations, elastic vibrations, and water friction. We will call the tension produced by the suspended weight, accelerations, elastic vibrations, and water friction *the imposed tension*. For the present we disregard the water friction.

We will consider a long resting cable with the piston core sampler suspended at its lower end. The weight of the core sampler will cause the rope to lengthen a certain amount. If the sampler is suddenly removed the cable will shorten, and as a consequence its lower end will be pulled upwards. The piston will pass by the point of equilibrium and will not stop until the cable has become as much shorter relative to the state of equilibrium as it was longer when the core sampler was attached to it. The piston will cover the whole distance at a constant velocity  $v$  cm/sec

$$v = \frac{P}{q\sqrt{Ed}}, \quad (1)$$

the denotations signifying:  $P$  dyn the weight of the core sampler in water,  $q$  cm<sup>2</sup>,  $E$  dyn/cm<sup>2</sup>, and  $d$  g/cm<sup>3</sup> respectively the sectional area, the elastic coefficient, and the specific gravity of the cable.

Having stopped, the piston will immediately start a downward motion, covering the same distance, and at the same velocity. It will go on vibrating in this manner until gradually stopped by friction.

When the cable is suddenly freed of the core sampler, there will start an elastic wave at the lower end, running up the cable at the

velocity of sound  $\left(= \sqrt{\frac{E}{d}}\right)$ . Having reached the top of the cable,

the wave will turn downwards, and thus it will go on running up and down the cable at the velocity of sound. In the wave front the conditions will be equal to those existing at the lower end of the cable at the moment the wave is started, *i. e.* the tension will change abruptly from one side of the wave front to the other with an amount equal to the weight of the core sampler. When the elastic wave is running up the rope for the first time, the imposed tension will be zero at every point passed by the wave, whereas it will be equal to the weight of the core sampler at every point not yet reached by the wave. Every point passed by the wave will be moving upwards at the same velocity as the piston, and every point not passed by the wave will be at rest. When the wave arrives at the ship, the whole cable will be moving upwards. Then the wave will be reflected and run down the cable, and now every point will come to rest when reached by the wave. The piston will continue moving upwards until the wave has returned to the lower end of the cable. At every point passed by the wave the imposed tension will be equal to the weight of the core sampler *with a negative sign*, which is only possible, however, in the parts of the cable where the tension produced by the weight of the cable exceeds the weight of the core sampler. In the lower parts of the cable the total tension will be zero, as it cannot be negative, it not being possible to *compress* the cable longitudinally at the low-frequency vibrations here considered. At the top of the cable, however, the elastic wave will announce the fall of the core sampler by diminishing abruptly the tension in the cable by *double as much* as the weight of the core sampler.

The period of the vibrations carried out by the piston will be determined by the time necessary for the elastic wave to run *twice* up and down the cable.

*Elastic Vibrations generated when the Lowering of the Cable is suddenly stopped* — We will now consider the same cable as before but moving downwards at a constant velocity  $v$ , and bearing no load but the piston at the lower end. We propose to investigate what will happen if the upper end of the cable is stopped suddenly.

A mathematical analysis will prove that a longitudinal elastic wave will be generated at the moment the cable is stopped. The wave will start at the top of the cable and run downwards at the velocity of sound. On arriving at the lower end it will be reflected, and thus it will go on running up and down the cable until the vibrations are gradually stopped by friction.

In the wave front there will appear a discontinuity of tension as well as of state of motion. When the wave is running down the cable for the first time, the imposed tension will be zero everywhere below the wave front, whereas it will have a certain constant value ( $= vq\sqrt{Ed}$ ) everywhere above the wave front. The part of the cable that is below the wave front will move downwards at the original velocity of the cable, whereas the part that is above the wave front will be at rest. Thus, the piston will not stop until the elastic wave has arrived at the lower end of the cable. Then the wave will run up the cable again, and behind it the cable will move upwards at the original velocity of lowering. The upward motion will go on until the wave returns once more. Thus, the cable will vibrate up and down, and the period will be the time necessary for the elastic wave to run *twice* up and down the cable.

*Immobilization of the Piston by combining the two Systems of elastic Vibrations* — When the piston core sampler is approaching the bottom at the end of a long cable, the cable will be suddenly freed of the heavy apparatus at the moment the core sampler falls off the release mechanism. That will start the first system of elastic vibrations in the cable. The piston will be pulled upwards at a velocity depending on the weight of the core sampler and the properties of the cable as expressed by equation (1). Therefore, if the cable is being lowered at the velocity determined by equation (1), the piston will come to a standstill at the moment the core sampler falls off the lever, and the piston will remain motionless until the elastic wave has travelled up and down the whole cable, running at the velocity of sound. If the depth amounts to 6000 m or more, the core sampler will have gone down into the mud to its full length

at the time the elastic wave returns to the lower end of the cable. Thus, at very great depth the piston will be immobilized without the cable being stopped at all, provided the cable is being lowered at the right velocity.

At a smaller depth it will be necessary to stop the lowering in order to immobilize the piston. When the lowering is stopped, a second system of elastic vibrations will appear in the cable. It will have the same periodicity as the first one, and it will have the same amplitude, provided the cable has been lowered at the right velocity as given by equation (1). Therefore the two systems of vibrations will extinguish each other provided they have opposite phases. That will be the case if the lowering is stopped at the moment the first elastic wave arrives at the top of the cable, announcing that the core sampler has reached the bottom.

It has been stated above that the tension in the cable at the top will be diminished by an amount equal to double as much as the weight of the core sampler (in water) at the moment the first elastic wave arrives at the ship. The cause of this is that the wave is reflected. The great change of tension will make it easy to stop the lowering of the cable at this very moment. As the abrupt stop of the lowering will produce an imposed tension equal to the weight of the core sampler, the imposed tension will now be zero everywhere. The lowering having stopped, the whole cable will be at rest.

*Influence of Water Friction* — In the analysis given above the water friction on cable and core sampler has not been taken into account. Obviously the friction will modify the events.

The drag of the core sampler during the lowering is easily taken into account, as it has only to be subtracted from the weight of the core sampler in water to make equation (1) valid. The drag of the core sampler during its fall has no bearing on the question at hand, *i. e.* the immobilization of the piston. However, during the fall of the core sampler the water pressure inside the coring tube will rise considerably, as the water is forced to leave the tube at a high velocity, and the pressure will exercise a downward force on the piston. This force, too, has to be subtracted from the weight of the core sampler to make equation (1) valid, as in the formula  $P$  stands for the change of tension brought forth by the release of the core sampler. By making the water exit port sufficiently small it should be possible to make the pressure on the piston almost balance the weight of the

core sampler, which would practically eliminate the elastic vibrations and facilitate the immobilization of the piston. This would necessitate a slow lowering speed in the vicinity of the bottom. It would involve a sacrifice of a great part of the advantage derived from the free fall of the coring tube.

The influence of the water friction on the cable is more complicated. We consider the core sampler approaching the bottom at the velocity given by equation (1). When the core sampler falls off the release mechanism, the piston will come to a stop. The elastic wave created at that moment will run up the cable at the velocity of sound. The «contracting velocity» of the cable at the wave front will be determined by equation (1) if  $P$  stands for the change of tension at the wave front, *i. e.* the difference of tension on both sides of the wave front. The imposed tension due to the core sampler is zero everywhere below the wave front (the pressure on the piston not considered for the present), and it has a certain constant value everywhere above the wave front. The imposed tension due to the drag of the cable is zero everywhere below the wave front *provided the cable is at rest there*, but above the wave front the imposed tension due to the drag of the cable has a negative value and is the larger numerically the greater the distance to the bottom and the higher the velocity of lowering. Therefore the change of tension at the wave front will diminish the more the distance to the bottom is increased. So the «shortening velocity» of the cable will diminish as the elastic wave travels along the cable, and the piston will begin to move downwards, the velocity being approximately the difference between the velocity of lowering and the shortening velocity of the cable.

The inconvenience due to the drag of the cable cannot be avoided completely, but it will be mollified if the cable is not lowered at the velocity determined by equation (1) but at a lower velocity according to depth and the design of cable. The piston will not be completely immobilized, but the errors will be small, and it will be possible to estimate them in order to apply corrections to the sediment depths measured in the cores.

#### THE OPERATING OF THE PISTON CORE SAMPLER

Owing to the heaviness and the great length of the piston core sampler it is necessary to make special arrangements for the operation of the core sampler on board.

It is advisable to set up a few stands on which the tube can be laid at a height convenient for work, *i. e.* about 90 cm above the deck. The stands should be carefully adjusted in order to keep the tube quite straight with no bending in any direction.

The lining tubes are introduced into the coring tube through its lower end, every tube being joined to the foregoing one with a collar as it is being pushed into the coring tube. This is continued until the topmost lining tube is stopped by the brass stop ring at the top of the coupling. Now, the packings being removed from it, the piston is inserted into the lining tube through the upper end, the piston rope being sufficiently stiff to push the top piece of the piston through the tube. When the piston appears at the mouth of the tube, the packings are fastened to it. Then the mouth-piece with the core catcher is brought into position, being screwed into the coring tube until stopped by the lining tubes. Thus the lining tubes are duly fixed in their position. As it is necessary to adapt the total length of the lining tube to the length of the coring tube, this should be done by an adequate shortening of the topmost lining tube. If that has not been done beforehand, the stop ring at the top of the coupling has to be removed, and then the topmost lining tube can be shortened. Then it will fit on all occasions, provided every lining tube is exactly 70 cm long.

The piston rope being run through the weight tube, the weight stand is attached to the top of the coring tube by means of the coupling. Finally, the release mechanism is brought into position and the piston rope is attached to the eye of the core sampler. The suspension link is attached to the short arm of the lever, and the safety link is attached to the long one.

Now the core sampler is ready to be hung out into the sea, which is performed in the following way. Three wrought iron clamps (Fig. 16) are laid round the tube, one at each end of the tube and one midway between them. The clamps are fixed in these positions, the lowest one by means of a funnel-shaped catch put over the mouth-piece and a rope connecting it with the other clamps. The

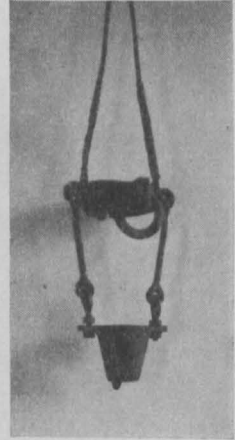

Fig. 16. A clamp and the funnel-shaped catch attached to it.

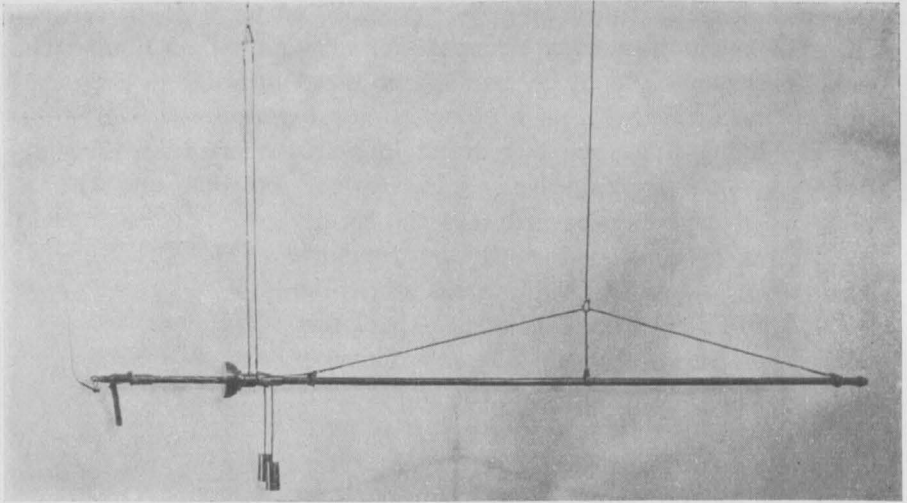

Fig. 17. The piston core sampler ready to be swung over board.  
(Photograph of a model.)

clamp near the top of the tube is attached there with a rope. Then a 10 mm rope is fastened to each clamp, the other end of the three ropes being kept together by a shackle, fastened in its turn to a rope intended to swing the tube over board. The counterweight stand being situated at the top of the coring tube, an auxiliary rope is shackled to the upper end of the counterweight rope.

The core sampler is lifted above the rail in a horizontal position, hanging there from two ropes, namely the counterweight rope and the rope connected to the three clamps (Fig. 17). Care should be taken not to hoist the counterweight rope until the tube is duly supported by the clamps, or else the tube might be bent. The core sampler is then brought outside the rail and lowered into the water, the mouth being there kept one or two meters below the top until the tube has been filled with water. Then the core sampler is brought into a vertical position by paying out the rope attached to the clamps until it is slack and by hauling in the counterweight rope until the top of the core sampler hangs conveniently high above the deck. The clamps are removed.

Semi-circular weights to the number considered necessary are put on the weight stand, the long sounding cable attached to the eye of the core sampler is hauled tight, the counterweight is lowered



to its position near the mouth of the tube, and the counterweight rope is attached to the long arm of the lever. Now the core sampler is hanging from the long cable.

At deep-sea coring with the heavy piston core sampler the correspondingly heavy sounding cable should not be allowed to run over a pulley high above the deck, as this would involve danger to life, it being impossible to keep the factor of safety sufficiently high to eliminate the risk of breakage. Therefore the sounding cable should run over a pulley situated immediately above the rail.

The preliminary operations being completed, the lowering of the core sampler can begin as soon as the safety link has been removed.

When the meter wheel announces that the core sampler has reached the vicinity of the bottom, the lowering velocity has to be adjusted as nearly as possible to the value calculated to extinguish the elastic vibrations of the cable that will be generated at the moment the core sampler slips off the release mechanism. The dynamometer should be kept under close observation, and as soon as the tension makes a sudden leap to a smaller value the lowering must be stopped immediately.

Sometimes the motion of the sea will call forth rather wide variations of tension, and then it is advisable for the person in charge of the dynamometer to take up his station sufficiently early to

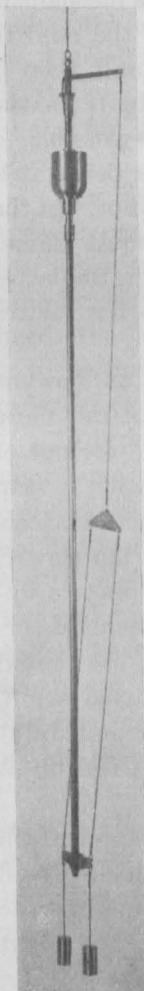

Fig. 19.

The piston core sampler during the lowering. (Photograph of a model.)

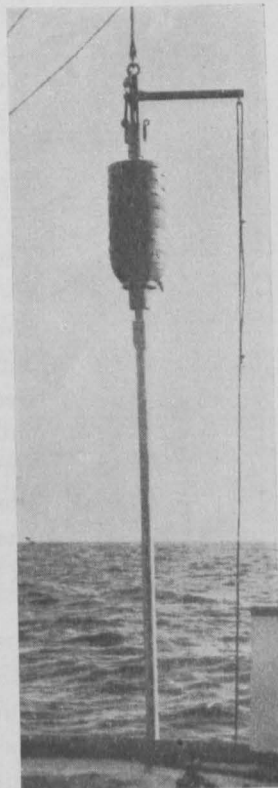

Fig. 18. The piston core sampler ready to be lowered.

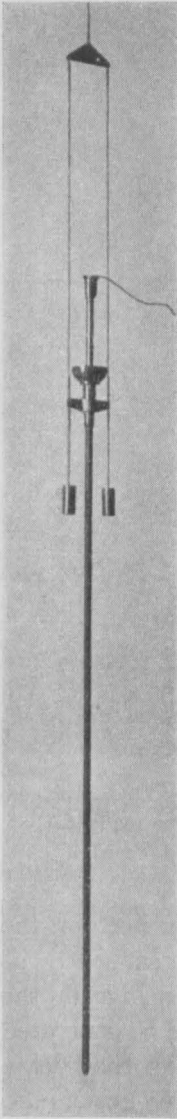

Fig. 20.

The piston core sampler ready to be taken on board.  
(Photograph of a model.)

get acquainted with the tension variations due to the motion of the sea. The variations will blur the critical relaxation, especially at great depths, where the relaxation is weakened owing to the fact that the water friction on the cable will disappear at the same time.

After having fallen off the release mechanism the core sampler will go down into the mud to its full length in 3 or 4 seconds, and then it should be allowed to stay one minute in the mud. When hauling is started it is possible to decide whether the core sampler has penetrated into the bottom to its full length or not. In the former case the tension will rise almost immediately the hauling begins, whereas in the latter case the tension will not rise until a few metres of the cable has been hauled in.

At first the hauling should be as slow as possible, and then the tension will not rise more than is necessary to pull the core sampler out of the bottom. In most cases it is advisable to stop the hauling when the tension has reached a certain value. Then the cable will shorten slowly, pulling the core sampler a few centimetres upwards, whereupon the tension will decrease correspondingly. As soon as the tension has ceased to decrease the hauling should be started again. After a few minutes the tube will be pulled out of the bottom, and then it may be hauled up at full speed.

When being hauled up the core sampler will hang on the piston. The release mechanism will be at a height above the apparatus equal to the length of the coring tube, and the counterweight will be near the top of the tube.

When the release mechanism has come up to the surface, the core sampler is swung on board in the following way. An auxiliary rope running over a pulley on the boom is shackled to the counterweight rope, which is then unfastened.

tened from the release mechanism. The auxiliary rope is hauled in until the core sampler is hanging from the counterweight rope. Then the piston rope is detached from the release mechanism, which is taken on board. After the core sampler has been lifted to a convenient height, the weights are removed. The clamps are then laid around the coring tube and are lowered down to their stations. The rope being adequately marked, the clamps are lowered until the undermost one has come down to the mouth-piece. Then the clamps are hauled up a few inches, whereby the funnel-shaped catch will be stopped by the mouth-piece. The uppermost clamp is fastened to the top of the tube, and then the three clamps are fixed in their places.

Now the rope attached to the clamps is hauled in until the core sampler has been brought into a horizontal position. The height of the apparatus having before that been adequately adapted, the core sampler will hang immediately above the rail. It can now be pulled inside the rail and laid down on the stands ready for it. When this is to be done the counterweight rope should be veered out first, in order to avoid the risk of bending the tube.

In order to secure the core the weight stand, the piston, and the mouth-piece are removed. The brass stop ring at the top of the coupling is also removed, and a round plate with an adequate rim is applied to the top of the lining tube. Then the lining tubes are taken out through the lower end of the coring tube, being pushed from the top end by means of iron tubes successively screwn together. The collars keeping adjacent pieces of the lining tube together are cautiously put aside, and then the core is cut off with a thin wire between the two brass tubes. The lining tubes are covered up until the core within them can be taken care of.

As the loose top layer will be spoilt when the core sampler is in a horizontal position the uppermost sediment layers should always be secured by means of a short core sampler. In order to gain time it might be possible to use such a core sampler as counterweight to the piston core sampler.

## PRACTICAL EXPERIENCES WITH THE PISTON CORE SAMPLER

The core-sampling technique described in this paper was developed during the war years, and it was then rarely possible to work outside Swedish territorial waters. In the summer of 1945 a few days' work could be done in the Skagerack at a maximum depth of about 700 m, and in the spring of 1946 the Swedish research ship the *Skagerak* went for a cruise to the western Mediterranean for the main purpose of putting the piston core sampler to a test in greater depths than those previously accessible. A short account of the cruise has been given by H. PETERSSON (10).

The leader of the expedition to the Mediterranean was Professor H. PETERSSON, and the other members were Professor W. WEIBULL, who carried out echo-soundings on the sediment thickness, and his assistant, Mr R. LUNDGREN, Dr O. NYBELIN, who was in charge of the biological work, Mr G. ARRHENIUS as mineralogist, and the present author, who was in charge of the core-sampling.

When working at a small depth it is advisable to anchor, as the cable is liable to acquire a critical inclination when the core sampler

Table 1. A few technical data about the core sampling in the Mediterranean in the spring of 1946.

Depth m	Tube length m	Core length m	Weight of core sampler kg	Time required for operations	
				Lowering and hoisting	Other operations
1400	11	0.8	720	2 <sup>h</sup> 00 <sup>m</sup>	50 <sup>m</sup>
2540	5.5	5	600	4 <sup>h</sup> 40 <sup>m</sup>	40 <sup>m</sup>
2420	11	10	850	5 <sup>h</sup> 25 <sup>m</sup>	50 <sup>m</sup>
2450	16	14	1300	3 <sup>h</sup> 00 <sup>m</sup>	1 <sup>h</sup> 45 <sup>m</sup>
2620	11	10	850	4 <sup>h</sup> 40 <sup>m</sup>	1 <sup>h</sup> 20 <sup>m</sup>
2320	11	8	850	3 <sup>h</sup> 10 <sup>m</sup>	45 <sup>m</sup>
2710	11	9.5	810	4 <sup>h</sup> 25 <sup>m</sup>	45 <sup>m</sup>
2810	11	10.5	810	3 <sup>h</sup> 35 <sup>m</sup>	45 <sup>m</sup>
2440	11	10	810	2 <sup>h</sup> 55 <sup>m</sup>	35 <sup>m</sup>
2620	16	15	1000	3 <sup>h</sup> 25 <sup>m</sup>	40 <sup>m</sup>
3620	11	10	650	8 <sup>h</sup> 40 <sup>m</sup>	50 <sup>m</sup>
1990	5.5	5	600	2 <sup>h</sup> 55 <sup>m</sup>	20 <sup>m</sup>
2720	11	8	560	2 <sup>h</sup> 25 <sup>m</sup>	30 <sup>m</sup>
2680	11	10	770	3 <sup>h</sup> 05 <sup>m</sup>	35 <sup>m</sup>
1850	11	10	770	2 <sup>h</sup> 25 <sup>m</sup>	30 <sup>m</sup>

Table 2. The depth of penetration of the piston core sampler in the Skagerack.

Position	Depth	Depth of penetration	Weight of the core sampler	
			kg	kg/m
58° 05' N, 10° 47' E	215 m	14.0 m	1400	100
58° 07' N, 10° 08' E	240	13.3	1360	102
58° 07' N, 9° 57' E	310	14.3	1080	76
58° 13' N, 9° 50' E	500	13.4	1360	102
58° 17' N, 9° 38' E	680	16.6 <sup>1)</sup>	1360	<82
58° 18' N, 9° 42' E	600	16.6 <sup>1)</sup>	1400	<84

is sticking in the mud if the ship is allowed to drift. This would involve the risk of bending or breaking the tube. At a great depth there is no such risk, as the inclination of the cable will then be much smaller.

A total of 17 cores were obtained in the Mediterranean. A few technical data are given in Table 1, and similar data about the core-sampling in the Swedish territorial waters and in the Skagerack are given in Fig. 21 and in Table 2.

As regards the character of the sediments, the deposits in the Skagerack consist mostly of a very stiff greenish grey clay, quite homogeneous and with no perceptible change with sediment depth. Except in the case of the Gullmar Fiord, where one or two thin sand layers appear, no stratification at all has been found down to a sediment depth of 20 metres in the Fiords and 15 metres in the open Skagerack.

In the Mediterranean off the Algerian coast and near the Balearic Islands the deposits consist of a rather stiff mostly grey clay with numerous sand layers as shown in Plate I, which is a photograph of a 13.8 metres long core obtained off Algiers (37° 50' N, 3° 11' E) at a depth of 2450 m. In the sand layers grains having a diameter of 0.1—0.3 millimetres are abundant, and grains having a diameter of more than 0.5 millimetres are not uncommon. Most of the grains are quartz, plagioclase, calcite, unidentified dark minerals, or shell fragments. Many Foraminifera shells are filled with small pyrite crystals, and some mineral grains are covered by such crystals. In the Tyrrhenian Sea the deposits consist of a rather loose, grey or brownish clay with numerous layers of volcanic cinders and some layers of globigerina ooze.

<sup>1)</sup> Some of the weights went down into the mud.

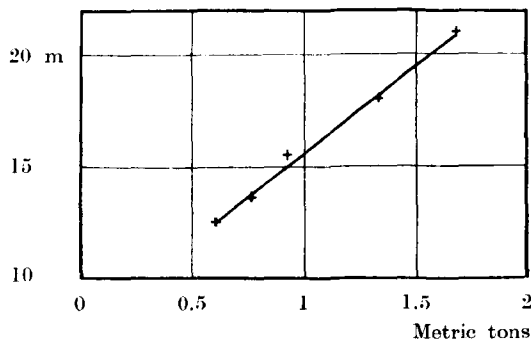

Fig. 21. Diagram showing the depth of penetration of the piston core sampler in the Gullmar Fiord. Initial velocity about 2 m/sec.

*The Weight of the Piston Core Sampler* — The question of the relation between the weight of the piston core sampler and the depth of penetration is of considerable interest for practical core-sampling work. Of course, there cannot exist a fixed relation that is valid in all cases, as the character of the sediment can alter between wide limits, vertically as well as horizontally. When a sufficiently thick layer is taken into account, such as 10—20 m, it may generally be assumed, however, that the average consistence of the sediment will be about the same in neighbouring localities, especially on the vast ocean areas. This has been found to be the case in the Skagerrack, where a stiff clay that offers great resistance to the coring tube is found everywhere but in the deeper parts near the Norwegian coast. It is also the case in the Mediterranean to the west of 6° E. longitude, where the sediment was found to offer about the same resistance to the coring tube at all the «Skagerak» stations.

In Fig. 21 the weight of the core sampler is plotted against the penetration depth, the observations being made at the same locality in the Gullmar Fiord on the Swedish west coast. The topmost sediment layers were a loose mud the resistance of which to the coring tube was quite insignificant. The water content of the sediment decreased very much with the depth below the bottom surface, and the deeper sediment layers were a very stiff clay that offered a great resistance to the coring tube. Whereas the resistance per metre increased with the depth in the top layers, it seems to be a constant in the deeper sediment layers. Between 12.5 and 21 m it is necessary

to increase the weight of the core sampler by about 130 kg in order to increase the penetration depth 1 metre.

Corresponding measurements have not been made in the open sea. In the Mediterranean, it is true, three cores were taken from one and the same locality ( $37^{\circ} 50' N$ ,  $3^{\circ} 11' E$ ), the penetration depths being respectively 5.5, 11, and 15.8 m. In all three cases the coring tube went down to its full length and some of the weights were covered with mud. Thus the core sampler was always unnecessarily heavy and therefore no definite conclusions can be drawn as to the relation between the weight of the core sampler and the penetration depth. In the western area of the Mediterranean investigated by the *Skagerak* the necessary weight of the piston core sampler seems to be less than 75 kg per metre, and in the Tyrrhenian Sea the corresponding figure can be estimated at 50 kg per metre.

*The Force necessary to pull the Coring Tube out of the Bottom* amounts to 150—200 kg per metre of penetration depth in the Swedish coastal waters and in the Skagerack, whereas the corresponding figure in the Mediterranean does not exceed 60 kg per metre of penetration depth. In the shallow waters in the Skagerack it is possible to use a very strong rope, and therefore the great force necessary to pull the coring tube out of the mud does not involve much trouble there. In deep water the factor of safety of the rope cannot be kept equally great. The retaining force exercised by the Mediterranean sediments is not dangerous even in the greatest ocean depths, but the forces met with in the Skagerack would be fatal at a great depth. Then it would be necessary to apply special arrangements with a view to facilitating the procedure. Such a device has been suggested by H. PETERSSON, and has been put to the test by the present author. The coring tube was provided with a tubular casing the inside diameter of which was a few mm larger than the outside diameter of the coring tube. The casing was fastened to the top of the apparatus by two or three wires just strong enough to bear its weight. When the core sampler had gone down into the sediment and was to be pulled out again, the wires broke and left the casing in the bottom. Then the core sampler could be hauled up without any frictional resistance at all.

*The Time required for the Operations* — The time needed to put the piston core sampler into the sea and make it quite ready to be

lowered as well as the time needed to take it on board again has been successively diminished until each operation is accomplished in about 20 minutes.

The time required to lower the core sampler to the bottom and to haul it home again is very much dependent on the qualities of the winch. The winch on board the *Skagerak* is old and not very well adapted to the present purpose. With a good winch it should be possible to obtain a core from a depth of 6000 m in about 4 hours.

*The Tension Variations called forth by the Motion of the Sea* — In some cases we had a comparatively heavy sea and that caused certain tension variations in the cable. They were never so large as to endanger the cable, keeping in most cases within  $\pm 500$  kg, but sometimes they threatened to blur the relaxation of tension announcing that the core sampler had gone into action. However, the critical jerk of the dynamometer has not once been overlooked.

In this connection it might not be out of place to relate an event proving the power of a long cable to endure a heavy twitch. Once, when the 11 m long core sampler weighing 720 kg was being lowered to the bottom, the long arm of the lever broke. This was due to some heavy jerks in the cable, caused by the winch, and to a badly made weld in the lever. As a consequence the core sampler fell until it was stopped by the piston, and everything involved, including the piston, the piston rope, and the long cable, was able to meet the shock without breaking, thanks to the fact that 1500 m of the cable had been veered out when the incident occurred. The elasticity of the long cable softened the shock very much. The cable had been delivered by the Hellefors Ropes Ltd., Hellefors, Sweden, and it had a breaking strength of 9.8 metric tons at a diameter of 12 millimetres.



## REFERENCES

1. EKMAN, F. L., K. V. A. Handl. XXV, No. 1, Stockholm 1893.
2. EKMAN, V. W., Cons. Int. pour l'Expl. de la Mer: Publ. de Circ. 27, 1905.
3. EMERY, K. O. and DIETZ, R. S., Geol. Soc. Am., Bull., 52, p. 1685, 1941.
4. HVORSLEV, M. J. and STETSON, H. C., Geol. Soc. Am., Bull., 57, p. 935, 1946.
5. JOLY, J., Proc. R. Dublin Soc., 14, p. 256, 1914.
6. KUENEN, PH. H., Ann. d. Hydr. u. Mar. Met., 60, p. 93, 1932.
7. KULLENBERG, B., Kolvlodet, Geol. För. Förh., 66, p. 501, Stockholm, 1944.
8. KULLENBERG, B., Medd. fra Dansk Geol. For., 10, p. 557, 1945.
9. OLSSON, J., Tekn. Tidskr., Väg- och Vattenbyggnadskonst, 55, p. 13, Stockholm, 1925.
10. PETERSSON, H., Geogr. Journ., CVII, p. 163, 1946.
11. PETERSSON, H. and KULLENBERG, B., Nature, 145, p. 306, 1940.
12. PETERSSON, H. and KULLENBERG, B., Medd. Oc. Inst. Göteborg, 5, 1941.
13. PIGGOT, C. S., Smithsonian Report, p. 207, 1936.
14. PIGGOT, C. S., Geol. Soc. Am., Bull., 52, p. 1513, 1941.
15. PRATJE, O., ZS. d. D. Geol. Ges., 70, p. 194, 1927.
16. PRATJE, O., Ann. d. Hydr. u. Mar. Met., 62, p. 137, 1934.
17. PRATJE, O., Ann. d. Hydr. u. Mar. Met., 67, p. 209, 1939.
18. VARNEY, F. M. and REDWINE, L. E., National Research Council, Report of the Committee on Sedimentation 1936—1937.
19. The SNELLIUS-Expedition, Vol. I, p. 74, Leiden 1938.

## PLATE I.

Sediment core from the Mediterranean. Lat. 37°50 N, long. 3°11 E. Depth 2450 m.  
Total length of core 13.76 m. The numbers refer to the sediment depth in centimetres.

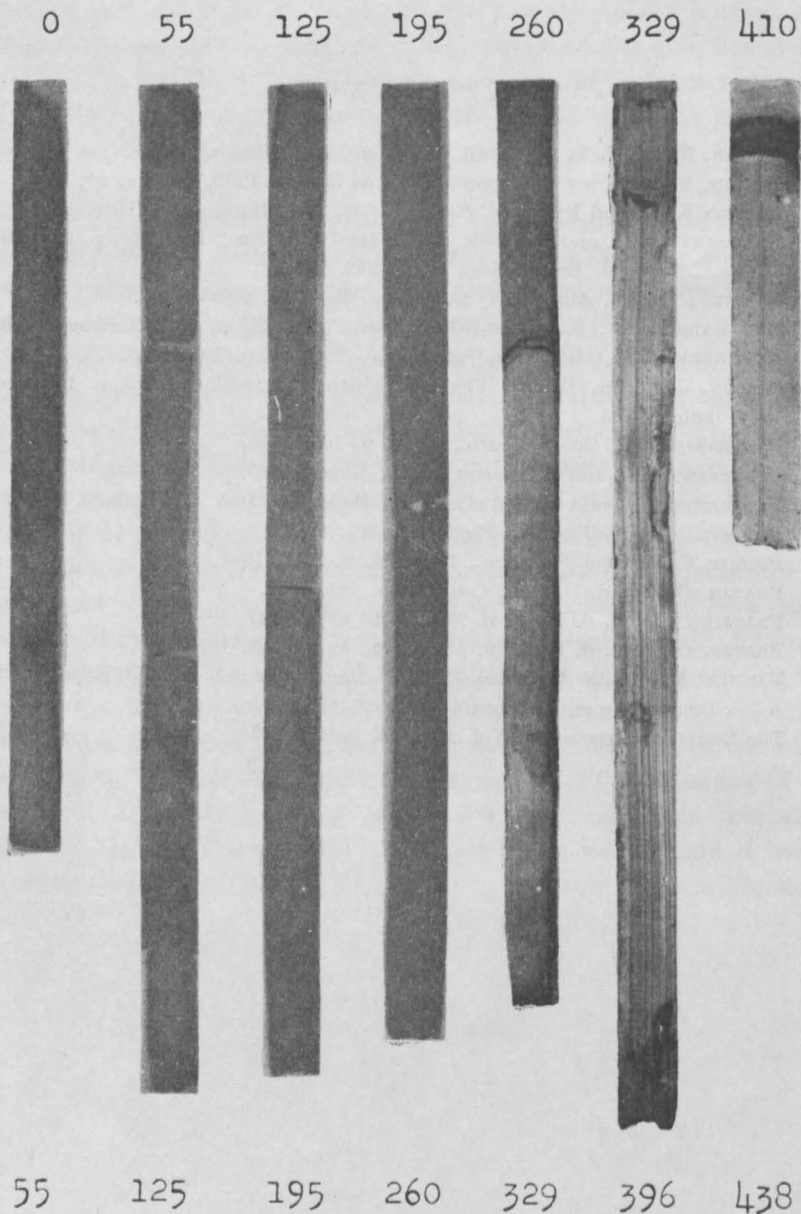

NOTE. Owing to the collapse of the lining tube part of the core was spoilt (396—410 cm).

Plate I, continued.

438

506

576

645

714

785

857



506

576

645

714

785

857

928

## Plate I, continued.

928 1000 1070 1141 1212 1282 1354

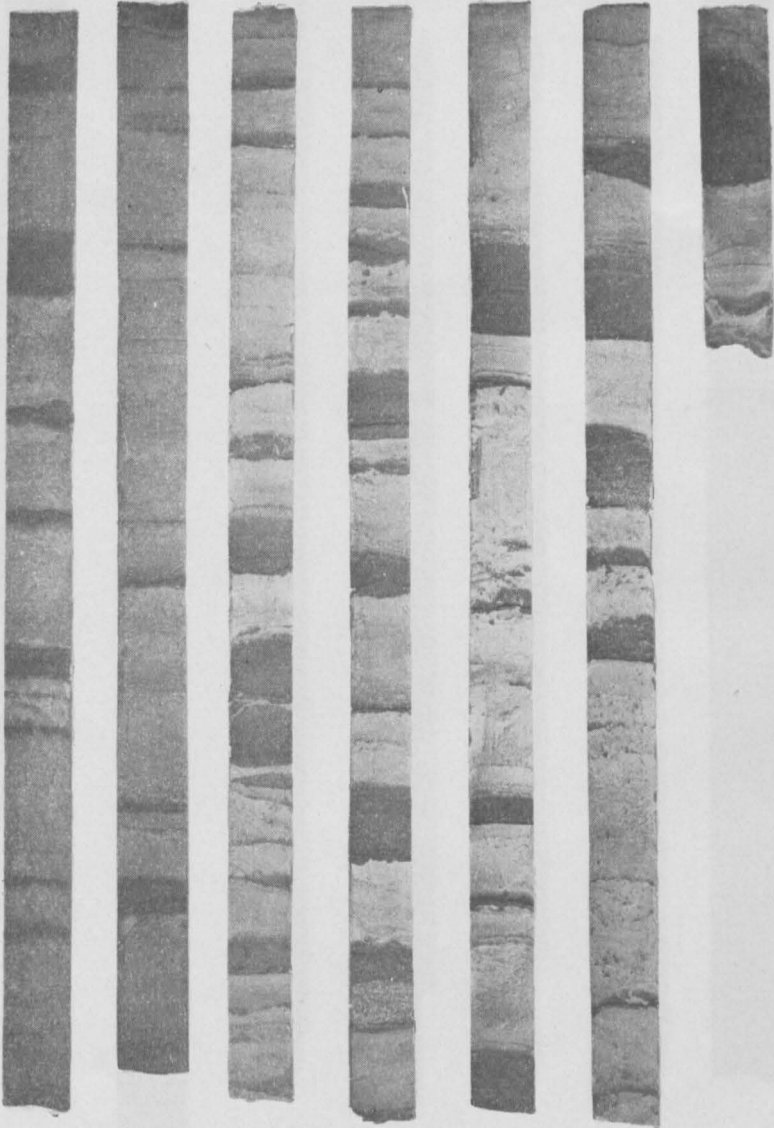

1000 1070 1141 1212 1282 1354 1376